



USER'S MANUAL

Waste disposal tanks type E0 to E2

1. Areas of application

In the course of increasing safety requirements collecting and disposal containers for the admission of used up chemicals became an important component in laboratories. Here the use of suitable collecting and disposal containers is an important point, in order to ensure safe jobs.

In many ranges the use of simple PE collectors is sufficient. With some materials or if a separation of different materials cannot be assured, collecting tanks from materials with special characteristics must be used. These special materials are for example PTFE or special glass (DURAN). Apart from the technical characteristics of collecting and disposal tanks also the optical recognition should be ensured by a suitable warning colour.

2. Mode of operation

The waste disposal tank type E 0 to E 2 is a surely standing collecting and disposal container furnished with a single-handed lid. The tank possesses an edge protection at bottom of gaiter, which ensures firm and safe conditions on the most different surfaces. Due to an easily moving bail that flaps aside after the tank was set down the star handle of the lid is easily accessible. The user needs only one hand to remove the lid by turning the star handle and flapping it sideward, after. The container now possesses a neck opening of 85 mm, into which the user can pour its materials or liquids easily. Filled-in materials or liquids encounter only the inner vessel (made of DURAN, special glass) and the lid. After substances were filled in user closes the tank by lifting the lid at the star handle and putting it on the glass threaded pip. Now the user can lock the tank by turning the star handle.

The standard version of the waste disposal tank possesses an overpressure valve, which opens with a pressure of 0,1 bar. This standard version is not suitable for inflammable materials, since an inflammable material must be grounded. For the use of such inflammable materials a special lid with grounding connection is offered.

3. Unpacking

Please unpack the tank carefully and pay attention to possibly damages. It is important that possible transport damages are already recognised when unpacking. If necessary, please take up the facts accurately and contact the manufacturer, then.

- Waste disposal tanks may only be used in above mentioned application
- For allowed operating conditions please see technical data under point 6
- Only from KGW-Isotherm admitted spare parts may be applied
- Tank must not be used when damages occur

4. Description of tank and components

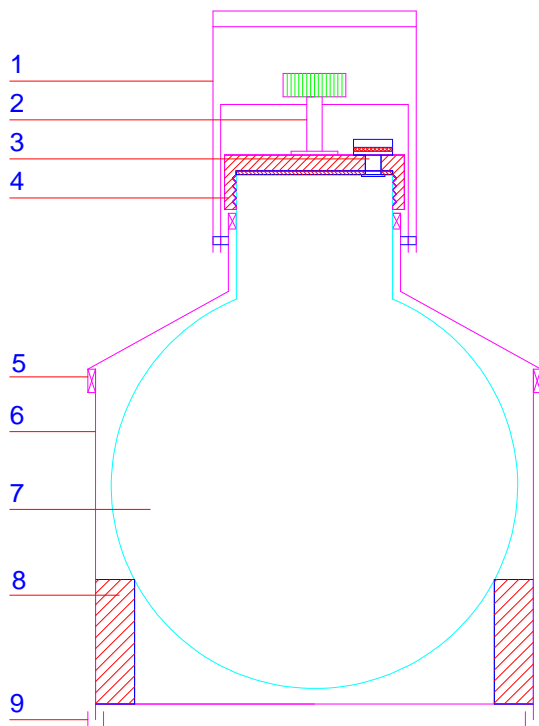

Tank consists of:

- 1) V2A carrying handle with protective rubber
- 2) Single-handed lock with star handle and supporting hoop out of V2A
- 3) Overpressure valve with PE mounting casing
- 4) Black PE lid with PTFE coated silicon seal disk
- 5) Protective rubber
- 6) Aluminium gaiter, red coated
- 7) Spherical storage tank out of Borosilicate glass 3.3 according to DIN/ISO 3585 with GL 90 glass thread
- 8) Buffer out of foamed PE
- 9) Edge protection

Standard lid with overpressure valve

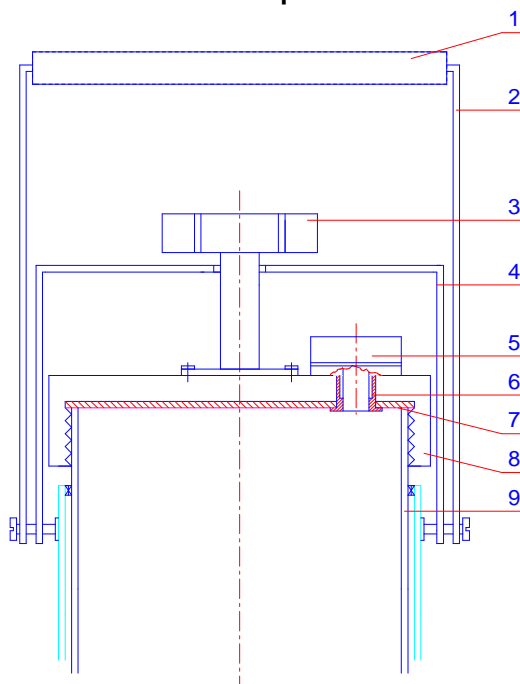

Component parts of standard lid

- 1) Protective rubber for carrying handle
- 2) Carrying handle out of V2A
- 3) Single-handed lock with star handle
- 4) Supporting hoop
- 5) Overpressure valve out of polyamide with NBR-sealing, PTFE coated; opening pressure: 0,1 bar
- 6) Mounting casing out of polyethylene, white
- 7) Lid sealant out of silicone, one side is PTFE coated
- 8) Black lid out of polyethylene
- 9) Glass thread neck out of Borosilicate glass 3.3 according to DIN/ISO 3585

Lid without overpressure valve

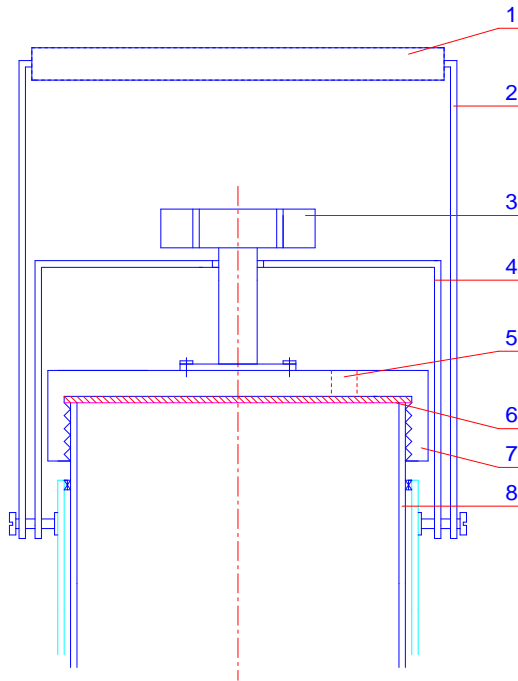

Component parts of lid without overpressure valve
(Special designed)

- 1) Protective rubber for carrying handle
- 2) Carrying handle out of V2A
- 3) Single-handed lock with star handle
- 4) Supporting hoop
- 5) Bore hole for overpressure valve
- 6) Lid sealant out of silicone, one side is PTFE coated; without valve bore hole
- 7) Black lid out of polyethylene
- 8) Glass thread neck out of Borosilicate glass 3.3 according to DIN/ISO 3585

Lid with ground connection

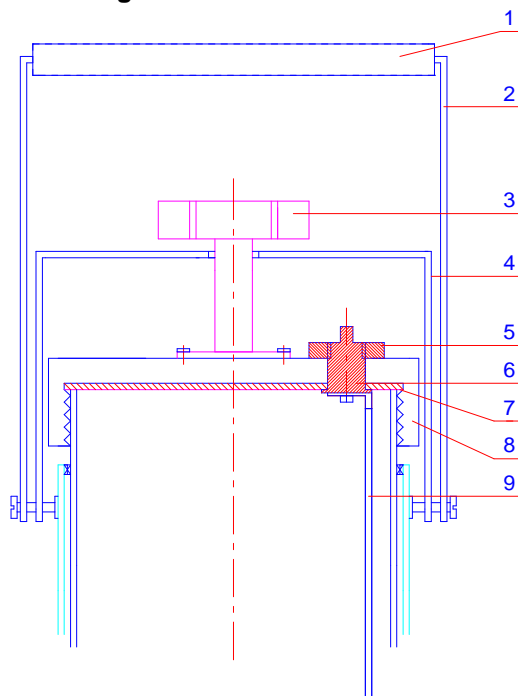

Component parts of lid with earth connection

- 1) Protective rubber for carrying handle
- 2) Carrying handle out of V2A
- 3) Single-handed lock with star handle
- 4) Supporting hoop
- 5) Locknut out of V2A
- 6) Earth connection block (copper) with connection pin and a contact screw for ground strap
- 7) Lid sealant out of silicone, one side is PTFE coated; with bore hole
- 8) Black lid out of polyethylene
- 9) Ground strap out of copper

5. Areas of application of the different catches

- a) The standard lid with an overpressure valve is used with liquids or solids, which can form a positive pressure by out gassing. Here it is to be made certain that the resulting gases do not attack the materials of seals and valve.
- b) The lid without overpressure valve is for the use of solids or liquids, those, which attack materials of the overpressure valve. This execution of the disposal can possess the highest chemical stability. No gassing materials or liquids may be stored.
- c) The lid with grounding connection is suitable for the employment by solids or liquids, which must be grounded, so e.g. inflammable substances. Here it is to be made certain that the materials stored in the container do not attack the materials of the seal and the grounding connection. Since no overpressure valve is present, no gassing materials or liquids may be stored.

6. Materials and their working temperature

- 1) The gaiter is made of aluminium and possesses a powder coating from GSB polyester (colour RAL 3000).
- 2) Interior container and the thread is out of Borosilicate glass 3.3 DIN/ISO 3585 (DURAN),
water resistance class 1 according to the DIN/ISO 719
acid resistance class 1 according to DIN/ISO 12116
alkali resistance class 2 according to DIN/ISO 695
working temperature: max.: 200°C
- 3) The black lid is made of polyethylene (PE)
working temperature: max. 200°C
- 4) The lid sealant is out of silicone (SI) with one-sided PTFE coating
working temperature: max. 200°C
- 5) Mounting casing out of polyethylene, white (PE)
working temperature: max. 80°C
- 6) Overpressure valve out of polyamide (PA) with PTFE coated NBR- sealant
working temperature: max. 120°C
- 7) Impact buffer out of foamed polyethylene (PE), white (Latzell)
working temperature: max. 60°C

A maximum working temperature of 60°C results from detailed statements of the waste disposal tank. The chemical characteristics of the individual materials can be taken out of table under point from 11.

7. Safety instructions

While handling chemicals, it is absolute to wear goggles, protective gloves and protective clothing. The kind of the protective gloves please infer from the technical data of your chemical. Depending upon chemical protective clothing is sometimes prescribed. Moreover, the general UVV and BG guidelines apply accordingly, as well as company internal guidelines, if any.

8. Maintenance and cleaning

The silicone sealant inside the lid should regularly be checked on visual changes and should in general be replaced at least within one year. The same check must be accomplished also at the overpressure valve. If such changes, or leakages of lid are realised the lid sealant or the entire lid must be absolutely replaced.

8.1 Cleaning

The interior container out of Borosilicate glass can be cleaned with all usual cleaning agents. The red coated gaiter may be cleaned only with water and tenside-containing cleaning agent. Please use a damp cloth for it.

9. Available spare parts

9.1 E 0

	Art. no.
- Spare lid (PE black) without sealant disk	1975
- Sealant disk with valve drilling	1993
- Sealant disk without valve drilling	1993-OB
- Glass refill E 0	1990
- Overpressure valve	1979
- Mounting casing for overpressure valve (PE white)	1999
- Buffer (PE white, foamed/Latizell)	E0-LA
- Edge profile of casing	1900-0
- Shock profile	1976
- Grounding connection, completely, for installing	1910
- Carrying handle with star handle	1989
- Star handle	1998

9.2 E 1

	Art. no.
- Spare lid (PE black) without sealant disk	1975
- Sealant disk with valve drilling	1993
- Sealant disk without valve drilling	1993-OB
- Glass refill E 1	1991
- Overpressure valve	1979
- Mounting casing for overpressure valve (PE white)	1999
- Buffer (PE white, foamed/Latizell)	E1-LA
- Edge profile of casing	1900-1
- Shock profile	1977
- Grounding connection, completely, for installing	1910
- Carrying handle with star handle	1989
- Star handle	1998

9.3 E 2

	Art. no.
- Spare lid (PE black) without sealant disk	1975
- Sealant disk with valve drilling	1993
- Sealant disk without valve drilling	1993-OB
- Glass refill E 2	1992
- Overpressure valve	1979
- Mounting casing for overpressure valve (PE white)	1999
- Buffer (PE white, foamed/Latizell)	E2-LA
- Edge profile of casing	1900-2
- Shock profile	1978
- Grounding connection, completely, for installing	1910
- Carrying handle with star handle	1989
- Star handle	1998

10. Technical specifications

Type:	E 0	E 1	E 2
Article no.	: 1625	1621	1622
Volume	: 4 Litres	8 Litres	15Litres
Outer diameter	: approx. 230 mm	approx. 265 mm	approx. 330 mm
Height	: approx. 360 mm	approx. 420 mm	approx. 450 mm
Weight, empty	: approx. 3,5 kg	approx. 4,5 kg	approx. 6,5 kg
Working temperature	: max. 60°C	max. 60°C	max. 60°C

11. Technical characteristics of the plastics

PE = polyethylene, PA = polyamide, SI = Silicone, PTFE = polytetrafluor ethylene

- + = very good chemical stability
- o = good to conditioned chemical stability
- = small chemical stability

Groups of substances	PE	PA	SI	PTFE
at 20°C				
acids				
- weak or diluted	+	+	o	+
- strong or concentrated	+	+	-	+
oxidizing agent	o	o	-	+
caustic solutions	+	+	+	+
alcohols, aliphatic	+	+	+	+
ketones	o	o	-	+
aldehydes	+	+	o	+
esters	o	o	o	+
hydrocarbons				
- aliphatic	o	+	-	+
- aromatic	o	o	-	+
- halogenated	-	o	-	+
ether	-	o	-	+

12. Warranty

During appropriate handling we grant a warranty of 12 months (starting from date of delivery of manufacturer). The warranty covers maximally the original cost of the container. In the case of warranty please contact the manufacturer.