

KGW-ISOTHERM

Germany
76185 Karlsruhe
Gablونzer Strasse 6
Tel. 0049 / 721 / 95897-0
Fax. 0049 / 721 / 95897-77
E-Mail: info@kgw-isotherm.de
Internet: [www.kgw-isotherm.de\(com\)](http://www.kgw-isotherm.de(com))

**Information and Operating Instructions for
Dewar Vessels Type 00 to S22C and G-C**



Typ C



Typ G-C

TABLE OF CONTENTS

1. Structure of an LN2 Container Type 00 to S22C or G-C

- 1.1 Description
- 1.2 Inner glass container with technical data
- 1.3 Outer cover with technical data
- 1.4 Dimensions and consumption data

2. Set up Instructions

- 2.1 Safety precautions when setting up the container

3. Operating Instructions

- 3.1 Transport
- 3.2 Handling
- 3.3 Inspection before Use
- 3.4 Filling and emptying
 - 3.4.1 Filling using a filling hose or funnel
 - 3.4.2 Emptying

4. Maintenance

5. Checking the Evaporation Rate

6. Spare Parts and Installation Information

7. General Safety Regulations with Liquid Gases

1 Structure of an LN2 Container Type 00 to S22C or G-C

1.1 Description

The container comprises two parts:

- a) The inner container made of borosilicate glass 3.3 for the storage of LN₂, CO₂ or other coolants or liquids ranging from +150°C to -196°C.
- b) The protective outer cover made of blue coated metal with or without side grip.

1.2 Inner glass container with technical data

The inner container is made of borosilicate glass 3.3 in accordance with DIN/ISO 3585 (DURAN).

The glass has the following characteristics:

Chemical characteristics	Water resistance: in accordance with DIN - ISO 719 (98°C) Water resistance: in accordance with DIN-ISO 720 (121°C) Acid resistance: in accordance with DIN - ISO 1776 Alkali resistance: in accordance with ISO 695 - A2
Optical characteristics	Spectral range: 310 - 200 nm in which the absorption is negligible.
Physical characteristics	Linear coefficient of expansion: $3.3 \times 10^{-6} \text{ 1/K}$ (at 20-300°C) Density: 2.23 g/cm ³ Specific heat capacity: 910 J/kg K Transformation temperature: 525 °C

Permissible operating conditions for the inner glass container with no lid

Dewar temperature range	- 196 to + 150 °C
Pressure range	Pressure-less

Standard Dewar vessels are not suitable for using with liquid and gaseous helium.

Standards and guidelines

The standard glass Dewar vessels, manufactured by KGW-ISOTHERM, are produced in compliance with the "Pressure Equipment Directive," Directive 97/23 EC (N4 with Annex 1) and in accordance with DIN 12492 "Equipment with Vacuum Insulation."

1.3.1 The blue coated metal protective cover Type C

The outer blue coated metal cover is purely a protective cover that protects the inner glass container from mechanical influences.

1.3.2 The blue coated metal protective cover and side grip Type G-C

The outer blue coated metal cover is purely a protective cover with side grip that protects the inner glass container from mechanical influences.

Permissible operating conditions for the protective cover with lid

Operating temperature of the protective cover to + 80 °C

Operating temperature of the lid: -196 to + 60 °C

1.4 Dimensions and consumption data of cylindrical Dewar vessels Type 00 to S22C or G-C

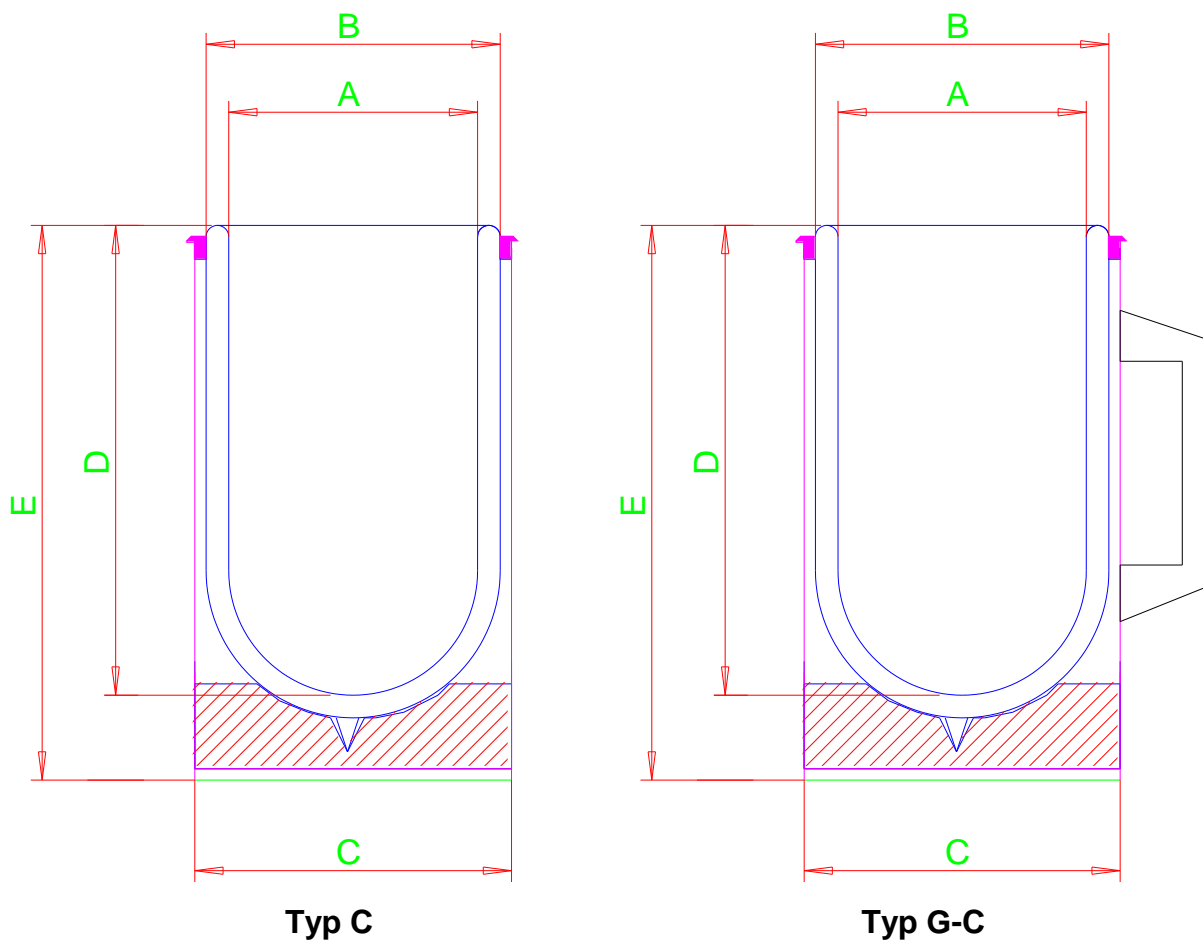

Technical Data

Technische Angaben / Technical Specifications / Caratéristiques techniques										
Type	max.Content						Weight	Holding time LN2	Evaporation rate LN2	
	ca. [ml]	mm	mm	mm	mm	mm	ca. [kg]	ca. [h]	ca. [L / d]	
00 C	100	40	56	63	90	135	0,2	7	0,3	
0 C	200	40	56	63	170	215	0,3	21	0,2	
1 C	300	47	60	72	190	240	0,3	31	0,2	
2 C	450	47	60	72	270	310	0,5	46	0,25	
3 C	500	57	70	81	210	260	0,5	30	0,35	
4 C	750	57	70	81	310	370	0,8	59	0,3	
5 C	1250	57	70	81	500	550	1,3	118	0,25	
6 C	800	67	80	90	240	295	0,6	54	0,35	
7 C	1200	67	80	90	350	395	0,8	98	0,3	
8 C	1700	67	80	90	500	560	1,1	136	0,3	
9 C	1000	77	95	105	235	290	0,7	60	0,35	
10 C	1500	77	95	105	345	395	1,1	80	0,4	
11 C	2100	77	95	105	500	550	1,8	130	0,4	
12 C	1500	90	115	124	245	300	1,1	53	0,5	
13 C	2000	90	115	124	340	390	1,4	90	0,5	
14 C	3200	90	115	124	600	665	2,5	193	0,45	
15 C	1500	100	120	130	240	300	1,2	49	0,7	
16 C	2000	100	120	130	290	345	1,4	77	0,6	
17 C	4000	100	120	130	600	660	2,9	156	0,65	
18 C	2500	110	130	140	290	345	1,7	74	0,7	
19 C	5000	110	130	140	600	660	3,2	207	0,6	
20 C	3000	138	160	165	230	280	1,4	55	1,2	
S 21 C	4000	138	160	165	310	375	2,4	92	1,0	
S 22 C	8000	138	160	165	600	660	4,6	220	0,9	
Article numbers										
Type	Article No.		Type	Article No.						
00 C	1021									
0 C	1022		G 0 C	1061						
1 C	1023		G 1 C	1062						
2 C	1024		G 2 C	1063						
3 C	1025		G 3 C	1064						
4 C	1026		G 4 C	1065						
5 C	1027									
6 C	1028		G 6 C	1066						
7 C	1029		G 7 C	1067						
8 C	10210									
9 C	10211		G 9 C	1068						
10 C	10212		G 10 C	1069						
11 C	10213									
12 C	10214		G 12 C	10610						
13 C	10215		G 13 C	10611						
14 C	10216									
15 C	10217		G 15 C	10612						
16 C	10218		G 16 C	10613						
17 C	10219									
18 C	10220		G 18 C	10614						
19 C	10221									
20 C	10222		G 20 C	10615						
S 21 C	10223		GS 21 C	10616						
S 22 C	10224		GS 22 C	10617						

Data on consumption data measured with plug

2 Set up Instructions

2.1 Safety precautions when setting up the container.

Before setting up or first using the container, read through and apply the safety regulations listed in point 7.

The following important points in particular should be noted:

- a) Wear appropriate protective equipment.**
- b) Nitrogen is neither toxic nor flammable but can lead to a lack of oxygen in closed rooms.**

It is therefore recommended that containers filled with liquid gas (especially when the liquefied gas is decanted into another container) are only used in an area with sufficient ventilation.

Always seal containers with the loose plug.

It is important to make sure that with the employment by gassing materials such as CO₂ or LN₂ a degassing hole is drilled into the lid, so that no positive pressure can form in containers.

Always place the container securely onto a work table. Ensure that it is not put too close to the edge of table. Avoid carrying the vessels by hand when transporting them via stairways as stairways always present a trip hazard and therefore liquid could escape should you stumble. Therefore, always use a lift for safety reasons.

Always carry the container using always with two hands or at the side grip and avoid the container swinging when transporting it as LN₂ could spurt out as a result.

3. Operating Instructions

3.1 Transport

The cylindrical Dewar vessels should only be used for in-house transportation. There is no ADR approval for road transportation.

Wear protective gloves, goggles and clothing if necessary when transporting the vessels. Furthermore, the internal in-house safety information or guidelines of the Employers' Liability Insurance Association should be observed.

3.2 Handling

The containers were designed in such a way that the glass insert is not damaged by minor knocks that cannot be avoided during handling. However, we strongly recommend the following in order to keep the LN₂ or CO₂ evaporation low and ensure that the glass container has a long service life:

- a) Avoid any hard knocks.**
- b) Always transport the container in an upright position.**
- c) Transport the container in such a way that any serious mechanical influences are avoided.**

A mobile roller base or transport trolley can be used to make it easier to transport containers within a laboratory.

3.3 Inspection before Use

Before using a Dewar container, a complete inspection must be made for scratches, cracks, chips or other flaws. Containers with surface flaws that will be subjected to mechanical or thermal stresses cannot be used due to the threat of implosion.

3.4 Filling and emptying

Protective gloves, clothing and goggles should generally be worn when handling liquid gases.

3.4.1 Filling

LN2 containers are filled using the following:

a) A filling hose with a phase separator that is inserted into the container. Ensure that the filling pressure in the hose does not exceed 1.5 bars so that the hose is stable and secure in the neck of the container during the filling process. The hose should not damage the glass wall. Secure the hose if necessary.

Alternative

b) A filling funnel that is placed on the neck of the vessel. A filling hose is inserted into this filling funnel and secured if necessary so that the filling hose or phase separator cannot touch the glass vessel.

When filling the container with CO₂ is to make sure that the CO₂ is brought carefully into the container. A surface damage of the glass is to be avoided.

3.4.2 Emptying the LN2

Remove the plug from the container and raise the container using the side grip or on the protective covering. A gripping edge on the base of the protective covering can be used to tip the container so that it is possible to safely handle and decant the LN₂ or another liquid.

4. Maintenance

The containers are generally maintenance-free. If the aluminum protective covering is damaged, check the connecting screws that connect the upper and lower section to each other. If the screws are damaged, the container must not be used until a repair is carried out.

5. Checking the Evaporation Rate

The evaporation rate of LN2 is checked by weighing the container with its liquid nitrogen content. This requires scales with a reading area that corresponds to the weight of the filled container and that provide sufficient accuracy when weighing.

Procedure:

Seal the container with a plug.

Weigh the empty container (M1).

Fill the container with liquid nitrogen and wait 3 to 4 hours until the temperature of the container has stabilised. Then fill it completely.

Weigh the full container (M2).

Read off the weight every hour. Deduct the weight of the empty container (M1) from the weighing result and log the data. This generates a stream of data from which the average weight loss in grams per hour can be determined for the period of time measured. If this value is converted with the specific weight of LN2 at approx. 800 grams = 1 litre, this gives the average evaporation rate per hour.

Note:

The room must remain at a constant temperature of 20°C and the atmospheric pressure must be held at 1,013 mbar during the measuring interval so that the measurement can be reproduced. The condition and age of the container obviously have a significant effect on the evaporation rate.

6 Spare Parts and Accessories

Article-number

Type	Article No.	Plug for Type	Article No.
00 A	1011	00	721
0 A	1012	0	1722
1 A	1013	1	1723
2 A	1014	2	1724
3 A	1015	3	1725
4 A	1016	4	1726
5 A	1017	5	1727
6 A	1018	6	1728
7 A	1019	7	1729
8 A	10110	8	17210
9 A	10111	9	17211
10 A	10112	10	17212
11 A	10113	11	17213
12 A	10114	12	17214
13 A	10115	13	17215
14 A	10116	14	17216
15 A	10117	15	17217
16 A	10118	16	17218
17 A	10119	17	17219
18 A	10120	18	17220
19 A	10121	19	17221
20 A	10122	20	17222
S 21 A	10123	S 21	17223
S 22 A	10124	S 22	17224

Mounting instruction for Cylindrical Dewar vessels

Types: 00 – S 22C and G-C

Safety instructions

When handling and working with Dewar containers, safety goggles/face protection and protection gloves must be worn!

- 1) Before mounting the Dewar vessel type A (No. 1) in the cover (No. 4), a complete inspection must be made for transport damages (scratches, cracks, chips or other flaws).
- 2) At first lay the cellular buffer (No. 3) into the cover.
- 3) Align the profile rubber (No. 2) on the top of the cover edge and damp it with soap-water or flushing agent. This reduces the frictional resistance between cover and glass.
- 4) The Dewar vessel should be pressed slowly and carefully in the profile rubber. The edge of the vessel (the seal) must be about 5 – 8 mm above the cover edge.

Attention: Face screen and protection gloves must be worn!

- 5) Dry the vessel for about 10 hours by room temperature. After that period of time the vessel can be used again.

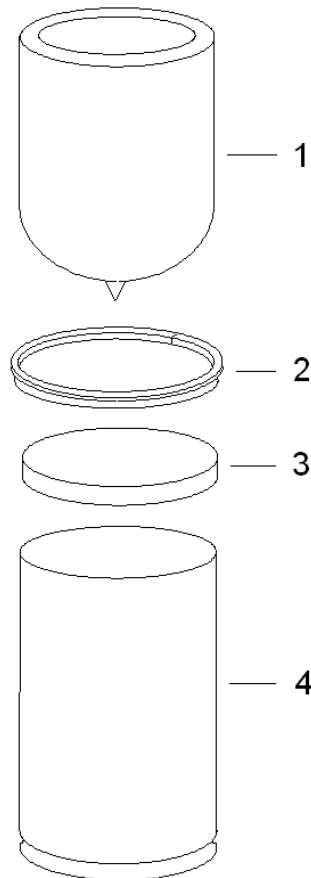

General Safety Regulations with Liquid Gases

This document contains general safety instructions in general, when using with liquid nitrogen.

The following instructions shall be respected while working with liquid nitrogen. To minimise the risk of accident and their consequences a few precautions should be taken, particularly related to:

- Oxygen deficiency
- Cryogenic burns
- Risks of explosion
- Oxygen enrichment

Once the users have been informed of risks and environmental conditions, all of them must be able to use liquid nitrogen in a safe way.

7 SAFETY INSTRUCTIONS

7.1 OXYGEN DEFICIENCY

The approximate composition of air by volume is as follows for its main components:

Oxygen O ₂	21 %
Nitrogen N ₂	78 %
Argon Ar	1 %

This gases are not toxic, but changes in their relative constituents, and particularly oxygen, have an effect on life and combustion processes. Therefore it is essential that the air we breathe should contain sufficient oxygen (> 19 %).

Our senses are incapable of detecting changes in the concentration of the constituents of air sufficiently quickly, since they are odourless and colourless.

7.1.1 Dangers

The risk of suffocation is high due to normal evaporation of liquid nitrogen to nitrogen gas that displaces oxygen in the inhaled air. For example, under standard temperature and pressure conditions (20° C; 1013 mbar), 1 litre of liquid nitrogen evaporates to 680 litres of nitrogen gas. The critical limit of oxygen can be easily reached. Oxygen deficiency is dangerous and can cause death from suffocation. The reaction of the organism to oxygen deficiency is different from one person to another. It is impossible to give any valid information in general about symptoms of a starting oxygen deficiency.

7.1.2 Causes

To protect yourself from risks of oxygen deficiency pay attention to following points:

- usage of liquid or gaseous nitrogen
- natural evaporation of liquid nitrogen
- refilling of liquid nitrogen
- leaks in storage tanks for liquid or gaseous nitrogen
- defective vent pipes or exhaust pipes
- tipping over the vessel

This list is not complete.

7.1.3 Recommendation

Proceed as follows to prevent the risks of oxygen deficiency:

- keep always the vessel in the vertical position
- close the vessel with an suitable lid
- do not put the vessel in bright sunshine or close to a heat source
- do not transport the vessel by car
- premises must always be well ventilated
- prevent strokes, avoid shocks and sudden movements
- wear always individual protective equipment (suitable gloves, safety goggles or protection visors and closed shoes)
- check the oxygen content continuously
- carry an oxygen meter
- train personnel

This list is not complete.

7.1.4 General behaviour to be followed in case of accident

Proceed as follows:

- mark the environment to prevent secondary accidents
- take action quickly: the rescuer must have taken individual protective measures (independent breathing protection apparatus)
- move the victim(s) away as quickly as possible
- pay attention to internal first aid rules of your plant
- ventilate the room sufficiently
- find out the reason of accident

This list is not complete.

7.2 CRYOGENIC BURNS

Liquid nitrogen is extremely cold (-196° C)

Parts of vessel that have been in contact with liquid nitrogen (especially while refilling) can burn the skin in case of contact.

7.2.1 Danger

Cryogenic fluids can:

- cause burns on the human body
- make materials (metallic or plastic) brittle in case they are not suitable for low temperatures
- cause strong nebulosity, depending on the air humidity of premise

7.2.2 Causes

There are two kinds of cryogenic burns:

7.2.2.1 Burns by splashes

It is important to protect yourself against the risk of splashes while using liquid nitrogen, especially when handling with samples. Splashes can cause cryogenic burns that can have serious consequences, especially when hitting eyes or face.

7.2.2.2 Contact burns

Contact between skin and cold materials causes frostbites or cryogenic burns. Never touch or grip the inner side of vessel or samples with a bare hand.

7.2.3 Recommendation

Proceed as follows to prevent the risks of burns:

- prevent skin contact with cryogenic liquids
- never touch the cold walls of vessel, or un-insulated or frosted equipment
- wear individual protection equipment (suitable gloves, safety goggles or protective visors and closed shoes)
- always hold the vessel in the vertical position
- use only suitable equipment (metal or PTFE hose) for refilling the container
- train personnel

This list is not complete.

7.2.4 General behaviour to be followed if liquid nitrogen is splashed

7.2.4.1 In the eyes

- wash the eye with a generous supply of water for at least 15 minutes
- pay attention to internal first aid rules of your plant
- consult a doctor

7.2.4.2 On the skin

- do not rub
- if possible, remove or loosen your cloths
- defrost affected parts by moderate and progressive heating
- do not apply anything on the burned area
- pay attention to internal first aid rules of your plant
- consult a doctor

Both lists are not complete.

7.3 THE RISK OF EXPLOSION

7.3.1 Dangers

The evaporation of liquid nitrogen can causes an overpressure inside of the vessels.

7.3.2 Causes

The increase of pressure in the vessel may happen due to:

- poor maintenance of the container
- accumulation of ice on the neck and the lid

This list is not complete.

7.3.3 Recommendation

Proceed as follows to prevent the risk of explosion:

- always use a suitable lid (pay attention to an exhaust gas opening)
- respect filling levels to prevent the formation of ice on the lid
- use the vessel only in dry and sheltered locations
- control the humidity of the room
- check vessel periodically with regards to accumulations of condensation water
- check vessel periodically with regards to surface defects and material damages

This list is not complete.

7.3.4 General behaviour to be followed in case of accidents

Please see above under 2.1.4, oxygen deficiency.

7.4 OXYGEN ENRICHMENT

7.4.1 Dangers

Oxygen enrichment can enlarge the risk of explosion or fire.

7.4.2 Causes

Oxygen enrichment, as a result of liquefaction of ambient air, can occur, because the boiling point of oxygen is high (-183° C) than the boiling point of liquid nitrogen (-196° C).

7.4.3 Recommendation

Proceed as follows to prevent the risk of explosion in case of oxygen enrichment:

- do not smoke
- eliminate easily inflammable products from the area of vessel, if possible
- eliminate all sources of fire (flames, sparks, matches, lighters, etc.)
- premise of vessel must be continuously and adequate ventilated
- clean the floor regularly
- train personnel
- wear individual protection equipment
- check the oxygen content continuously
- always wear an oxygen meter

This list is not complete.

7.5 ENVIRONMENT OF VESSEL

7.5.1 The premise

The premise of vessel shall:

- enable safe operation for participants
- enable a safe refilling of vessel
- be continuously and adequate ventilated
- have a flat and non-porous floor, capable of resisting the maximum load of vessel
- include posters (safety data sheets) mentioning the dangerous properties of liquid nitrogen
- prevent access to unauthorised persons
- enable a good accessibility of vessel for inspection, cleaning and maintenance

This list is not complete.