

Information about Installation and Occupational Safety for double-walled Glass reaction vessels

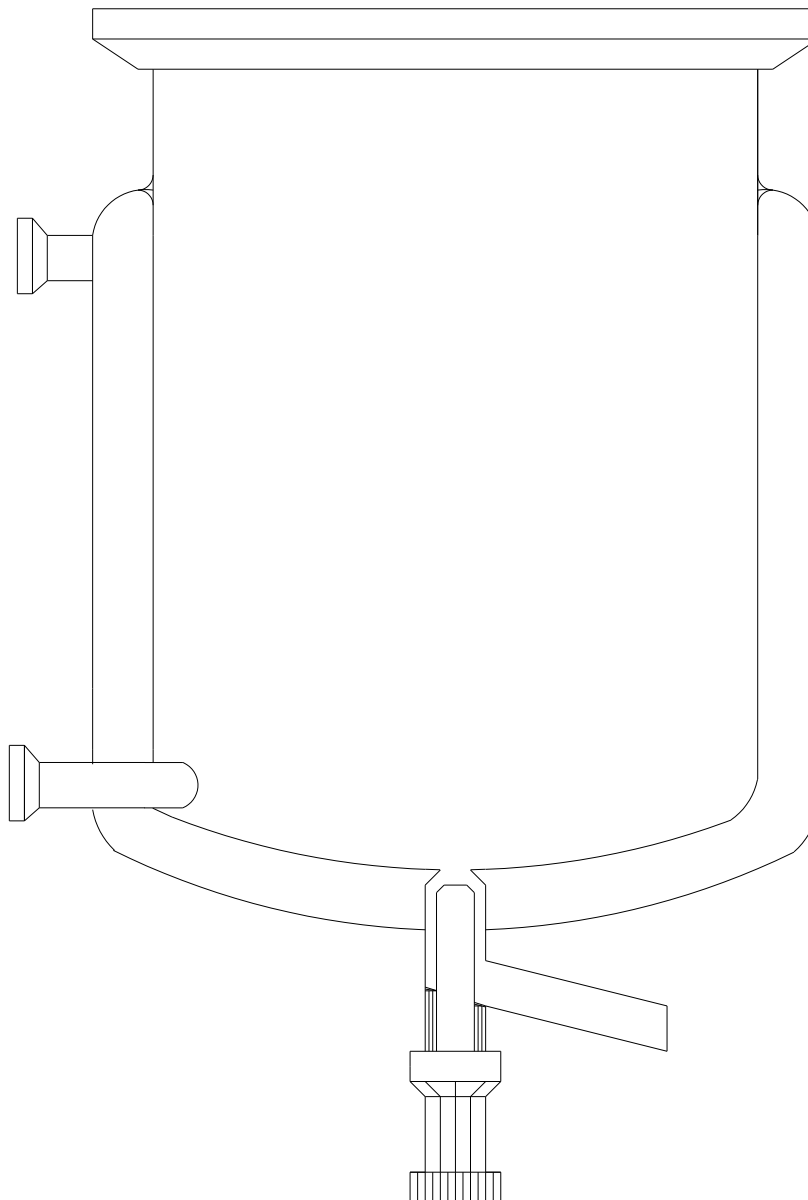

KGW-ISOTHERM

Gablonzer Straße 6
76185 Karlsruhe
Germany

Tel: 0049 / 721 95897-0

Fax: 0049 / 721 95897-77

Internet: www.kgw-isotherm.de

e-mail: info@kgw-isotherm.de

**Double-walled reaction vessels**

ATTENTION!! Implicitly read manual before unpacking and installation of the vessel !!

Table of contents

1	Safety advices	3
1.1	General Safety Information for Vessel owner	3
1.2	General Safety Information for Vessel operator	3
1.3	Warning labels	3
1.4	Qualification of staff	4
1.5	Danger of ignoring the Safety Information	4
1.6	Alteration without authority and spare parts	4
1.7	Correct and Incorrect Operation	4
1.8	Safety information for operation in explosive surrounding	5
2	Liability for Defects as to quality	5
3	Transportation	5
4	General Information	5
4.1	Manufacturer's Declaration	5
4.2	Design	6
4.3	Specifications / Limits of Use	6,7
5	Assembling Triple-Walled Vessels	8
6	Putting Into Operation	9
7	Maintenance / Servicing / Repairs	9
8	Diagram of a Double-Walled Reactor	10



1 Safety Information

1.1 General Safety Information for Vessel Owners

This operating manual contains basic information on setting up, operating and servicing your vessel. The vessel owner and designated personnel should (a) read this manual before performing any such activities, (b) follow its instructions while performing the activities, and (c) make sure the manual is available wherever the triple-walled vessel is being used.

They should also follow the following rules:

- All applicable national regulations on accident prevention, electrical equipment, static electricity, transportation equipment, environmental protection and explosion prevention
- The vessel owner's in-house process specifications, operating instructions and safety regulations

If you have any questions, please contact KGW-ISOTHERM in Karlsruhe, Germany.

1.2 General Safety Information for Vessel Operators

- Do not perform any activity that could make the double-walled vessel and/or the system less safe.
- As a general rule, you should only work on the double-walled vessel once it has gone out of operation and reached ambient temperature.
- Before disassembling the vessel, make sure it does not contain any substances that are hazardous to the environment and/or human health.
- Once you are finished with your work, you must immediately re-attach all the protective and safety devices.
- Before performing any maintenance or repairs, you must ensure that the apparatus cannot be turned on again.

1.3 Types of Safety Warnings

This operating manual contains safety warnings that, if not followed, could pose a serious health hazard. These warnings are labeled as follows:



General hazard symbol



Electrical voltage warning

Warning

Safety warnings that, if not followed, could pose a risk to the vessel and its functionality



Personnel Qualifications

The employees who assemble, connect, test-run, operate, service and eliminate faults on the vessel must be appropriately qualified or adequately trained.

The vessel owner must:

- Make clear arrangements regarding personnel responsibilities and supervision
- Ensure the personnel fully understand the contents of the operating manual(s)

1.4 Hazards of Ignoring the Safety Warnings

If you ignore the safety warnings, you could put yourself, other personnel, the environment and the vessel (as well as the apparatus/system) at risk, and free KGW-ISOTHERM of any and all liability for defects as to quality.

The hazards of ignoring safety warnings include:

- Injuries due to electrical, mechanical or chemical influences
- Problems with important functions
- Environmental pollution from hazardous material leaks

1.5 Alterations and Spare Parts

The vessel owner may only alter or modify the double-walled vessel in consultation and agreement with the manufacturer. For your safety, you should only use original spare parts and accessories authorized by the manufacturer. Using other parts may render the manufacturer's liability for any consequences null and void.

1.6 Correct and Incorrect Ways to Operate the Vessel

The vessel must be operated as indicated in this manual (4.3 – 7) to ensure adequate safety. If you operate the vessel in any other way or with media which may attack the vessel materials, we may disclaim any and all liability for the consequences. Also: The vessel may only be operated if it is in flawless condition.

1.7 Safety Warnings for Operations in Explosive Areas

If you operate glass apparatuses in explosive areas in a way that may lead to explosive discharges of static electricity, you must take appropriate precautions. The extent of these precautions depends on the probability that an explosive atmosphere will be created. This probability (in terms of time and location) is broken down into zones that depend on the areas in which the device is to operate. The zones correspond to the Equipment Categories laid out in Directive 94/9/EC.

For more details on how electrostatic ignition hazards are caused, evaluated and avoided, please consult Guideline BGR 132 on static electricity issued by BG Chemie.



2 Liability for Defects as to Quality

Our liability for defects as to quality is as laid out in our General Terms and Conditions of Sale and Delivery as they may change from time to time. Please notify us immediately if damages occur during the contractually agreed upon period. This is the only way you can safeguard your rights to a remedy in case of defects as to quality.

We are only liable if the permitted operating conditions were complied with and the material's resistance to the media was considered. As set forth in our valid Terms and Conditions of Sale and Delivery, we disclaim all liability for damages sustained by the failure to observe these requirements.

3 Transportation



Any transportation must comply with generally accepted technical conventions, accident prevention regulations, regulations on handling and using transportation and lifting equipment (including the manufacturer's instructions), and in-house safety rules.

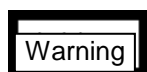

Every double-walled vessel is delivered packaged in boxes / cases. The vessel must be protected against shock, impact or any other mechanical stress when you unpack the parts and transport them on your own premises.



Keep people outside of the hazard area.

4 General Information

4.1 Manufacturer's Declaration

The double-walled vessel was manufactured by

KGW-ISOTHERM GmbH
Gablonzerstrasse 6,
D-76185 Karlsruhe, Germany
Phone (0049 / 0721) 95897-0
Fax (0049 / 0721) 95897-77
E-mail: info@kgw-isotherm.de

Please contact the manufacturer if you have any questions about assembling, connecting, operating, servicing, repairing, or eliminating faults on the vessel.

4.2 Design

Double-walled vessels contain two walls that have been fused together. The space between the inner and the outer wall is filled with the tempering medium.

You will generally have to install a pressure relief device rated at 0.5 bar before you can fill the vessel with a liquid tempering medium.

4.3 Technical data / Operation limits

The vessels can be delivered with different tempering casing connections. These have different operating temperatures. (Standard GL18 with PTFE olive or DN 15 Glass flask)

- Tempering casing connection GL18 with PTFE olive, operating temperature -10 to $+120$ °C
- Tempering casing connection DN 15 depending on gasket, operation temperature -120 to $+200$ °C

4.3.1 Mounting and Installation of metal adapter

Mounting

- Glass flask DN 15
- Cover screw nut with installation clip
- Gasket
- Metal adapter with screw thread M16x1 for metal tubes

Installation

- The metal clip is pulled out of the cover screw nut (no.2)
- Then the cover screw nut is moved over the glass flask (no 1) and afterwards the clip is pulled back into the borehole of the cover screw nut
- The gasket (no 3) is inlaid into the casing of the metal adapter (no 4)
- The casing of the metal adapter (no 4) is moved onto the glass flask (no 1) and tightened by means of the cover screw nut (no 2)
- Finally, the metal tube of the thermostat can be connected with the metal adapter (no 4)

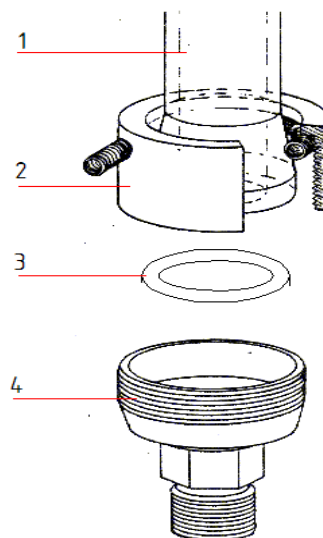

Spare parts

- | | |
|---|----------------|
| A) Metal adapter, complete for DN 15 | Order no. 4200 |
| B) Silicone Gasket | Order no. 4201 |
| C) PTFE Gasket | Order no. 4202 |
| D) Metal tubes, thermal insulated up to 300°C | |
| Connections thread M16x1 | |
| - Length 1.0 metres | Order no. 4216 |
| - Length 1.5 metres | Order no. 4217 |
| - Length 2.0 metres | Order no. 4218 |

The vessels can be delivered with different ground drain valves. These have different operation temperatures. (Standard L-valve and J-valve)

- a) Ground drain, type J-valve with spring pressure loading PTFE-plunger, to guarantee uniform closing forces at fluctuating temperatures. Operation temperature -120 to 200°C
- b) Ground drain, type L-valve with PTFE-plunger, operation temperature -10 to $+130^{\circ}\text{C}$

4.3.2 Industry valve Type „J“

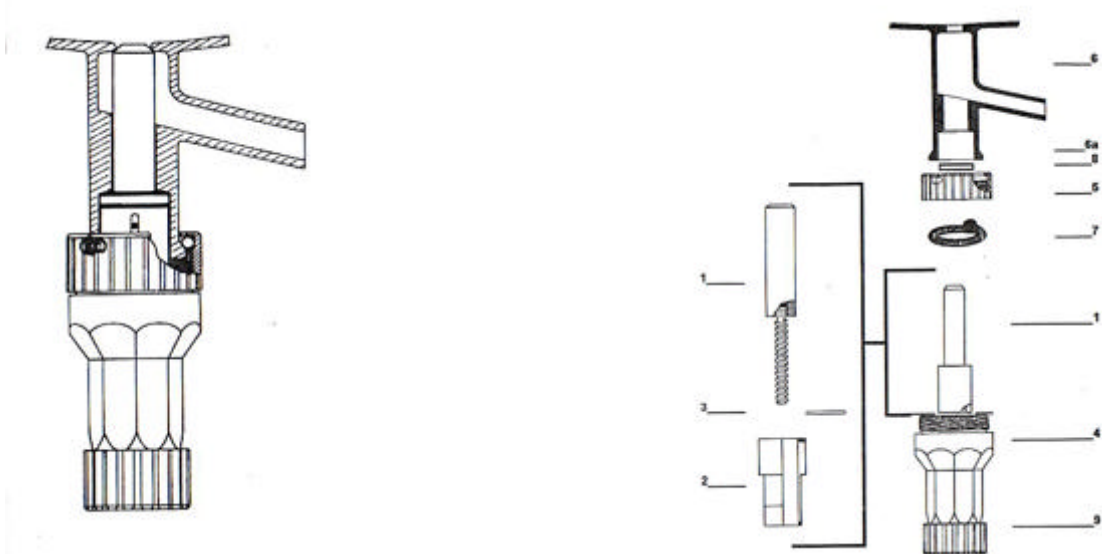

Installation manual for J-valve , drain valve type “J”

- A Insert valve-plunger (1) into guide sleeve (2) and secure with split-pin (3). Then screw it, with V2A-thread side, anti-clockwise into the valve-body (4) as far as possible. Doing this, the square of the guide sleeve has to be inserted in the corresponding borehole of the valve-body.
- B Screw the counter nut (5) one turn on valve-body.
- C Insert gasket (8) into glass flask (6a) and push it to the constriction.
- D Move valve as far as possible into the glass part and insert stainless steel clip (7) into the tangential borehole of the counter nut, right to the widening. Afterwards, tighten counter nut until the guide sleeve bears on the gasket. By further tightening of the counter nut, the pressure to the gasket can be increased or decreased.

Attention: Do NOT tighten counter nut by too strong force, since this causes high wastage of the gasket!!

- E By turning the button (9) counterwise, the valve can be closed. The maximum stroke length of the drain valve is 50 mm, this can be used to full capacity. In order to guarantee the function of the safety clip installed in the valve, the button has to be twirled about 2 turns further after stop position of the valve top, this is equal to 5 mm possible safety feed.

General information

As long as the split-pin is not yet visible in the valve-body, the safety clip can be retightened by twirling the button. If the split-pin gets visible and undercuts a distance of about 5mm to the end of the guide track, a replacement of the valve-plunger is recommended, as the plunger top is worn-out and with that the safety feed has decreased in equal measure.

If desired, the vessels can be delivered with other tempering cover connections or ground drains.

5 Installation of double-walled vessels

While working with reaction vessels, wearing of safety glasses or face protection as well as safety gloves is prescribed and necessary!

The installation of glass components into KGW-stands or customer-owned mountings is to execute by competent skilled staff. The installation has to effect in de-energized status.

All exterior connections of the double-walled vessels are to connect in de-energized status.

The mounting of multi-walled, fused-together glass vessels effects by the standard connectors of stainless steel with carrier ring or on aluminium plates (type Easy Frame) in a stand that overtakes, as an anchor point, the entire weight of the vessel.

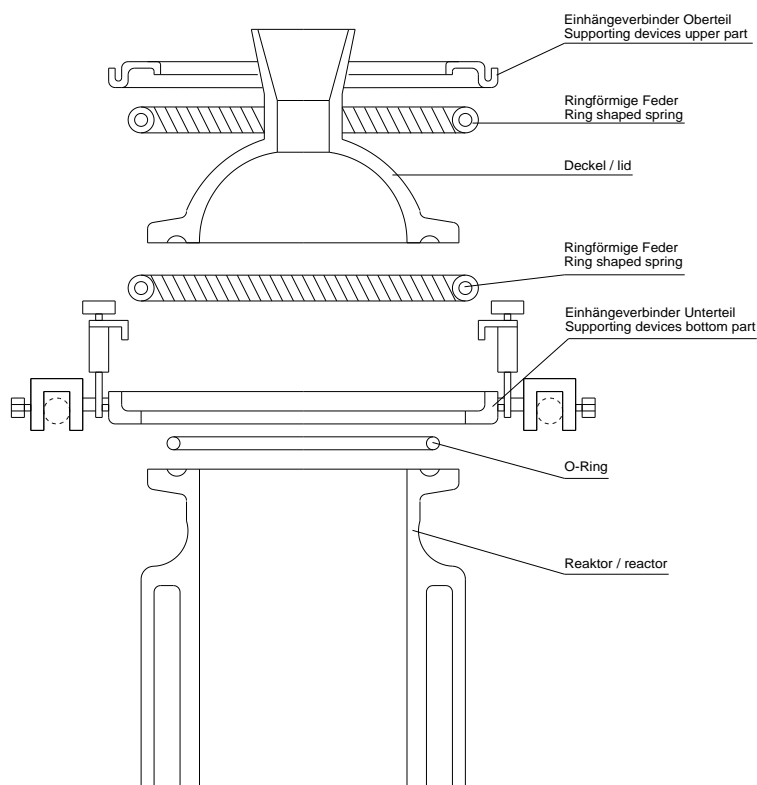

As a further safety means, the vessel should additionally be installed in a casing / protector of transparent synthetic material, in order to protect the operator in case of a destruction of the vessel.

It is regulated to equip both the product space and the tempering cover with an overpressure locking against exceeding the maximal allowed operation-overpressure.

For eventuell necessary cleaning processes, it can be required to dismantle the ground drain valve. The re-installation should, in every case, effect with opened valve, as otherwise a damage of the valve top or plunger is possible.



6 Putting into Operation

Before usage of the vessel, the operator has to check it in view of damages on the surface like scratches, cracks, etc – interior and exterior.

Also check for chemical degradation on the glass surface.

Vessels with damages on the surface, degradation signs etc cannot be used because the component can implode under thermal / mechanical pressure.

Starting operation, any start-up processes are to avoid that could lead to pressure impacts. The temper medium circulation is to de-aerate completely in depressurized status.

During start-up and run-down processes, a slow boost / reduction of the circulation stream is obligatory. By fast switch off / on of the circulation stream, pressure impacts can be created, that can effect a destruction of the vessel.

In addition to the mentioned operation conditions, it is to observe urgently, that the speeds (of 30K/min) of heating-up and cooling-down in the tempering cover may not be exceeded.

Due to the special construction of the double-walled vessel, it is urgently necessary that the temperature of the medium does not differ more than 50 K from the temperature of the tempering cover during the filling process of the empty vessel.

During the metered addition of medium in a filled vessel with differing temperatures of product and added medium of more than 50 K, a direct blow against the wall is to avoid.

7 Maintenance / Care / Reparatons

Using products that tend to degradations, it has to be observed while closing the valve that no solid particles
Bei zu Ablagerungen neigendem Produkt ist darauf zu achten, daß sich beim Schließen des Ventils keine Feststoffpartikel im Bereich des Ventilstempels und/oder Ventilsitzes befinden. Ablagerungen führen zu Undichtigkeiten und können ggf. das Ventil beschädigen.

Gefäße mit Beschädigungen dürfen nicht mehr in Betrieb genommen werden.
Für notwendige Reparaturen setzen Sie sich bitte mit dem Hersteller in Verbindung.

8 Darstellung eines Zweiwandreaktors

