



## Karlsruher Glastechnisches Werk ISOTHERM

Gablonzer Straße 6  
D - 76185 Karlsruhe  
Phone +49-(0)721 / 95897-0  
Fax +49-(0)721 / 95897-77  
eMail: [kgw-isotherm@t-online.de](mailto:kgw-isotherm@t-online.de)  
<http://www.kgw-isotherm.com>



### Operating Instructions

**Kaltgas System Type TG-LKF-H  
KF NW 40 for direct tempering by  
means of a constant N<sub>2</sub> gas flow.**

## **Contents**

- 1) Safety instructions**
- 2) Function and description of plant**
- 3) Unpacking and initial inspection**
- 4) Components of Kaltgas System Type TG-LKF-H**
- 5) Installation**
- 6) Handling and function of safety controller**
- 7) Commissioning of LN2 tank Type Apollo with LN2**
- 8) Commissioning of Kaltgas System**
- 9) Settings**
- 10) Safety instructions**
- 11) Maintenance and cleaning**
- 12) Troubleshooting**
- 13) Technical specifications**
- 14) Warranty**
- 15) Troubleshooting in Kaltgas Systems**
- 16) Declarations of conformity**
- 17) Layouts**
- 18) Detail sketch of hose**
- 19) Test run data**

## **Separate manuals**

- 1) Kaltgas software with free Software**
- 2) Kaltgas Data with program**

# **1 Safety instructions**

## **1 IN GENERAL**

## **2 SAFETY INSTRUCTIONS**

### **2.1 OXYGEN DEFICIENCY**

#### **2.1.1 Dangers**

#### **2.1.2 Causes**

#### **2.1.3 Recommendation**

#### **2.1.4 General behaviour to be followed in case of accident**

### **2.2 CRYOGENIC BURNS**

#### **2.2.1 Danger**

#### **2.2.2 Causes**

#### **2.2.3 Recommendation**

#### **2.2.4 General behaviour to be followed if liquid nitrogen is splashed**

### **2.3 THE RISK OF EXPLOSION**

#### **2.3.1 Dangers**

#### **2.3.2 Causes**

#### **2.3.3 Recommendation**

#### **2.3.4 General behaviour to be followed in case of accidents**

### **2.4 OXYGEN ENRICHMENT**

#### **2.4.1 Dangers**

#### **2.4.2 Causes**

#### **2.4.3 Recommendation**

### **2.5 ENVIRONMENT OF VESSEL**

#### **2.5.1 The premise**

## **1 IN GENERAL**

This document contains general safety instructions in general, when using with liquid nitrogen.

The following instructions shall be respected while working with liquid nitrogen. To minimise the risk of accident and their consequences a few precautions should be taken, particularly related to:

- Oxygen deficiency
- Cryogenic burns
- Risks of explosion
- Oxygen enrichment

Once the users have been informed of risks and environmental conditions, all of them must be able to use liquid nitrogen in a safe way.

## **2 SAFETY INSTRUCTIONS**

### **2.1 OXYGEN DEFICIENCY**

The approximate composition of air by volume is as follows for its main components:

Oxygen O <sub>2</sub>	21 %
Nitrogen N <sub>2</sub>	78 %
Argon Ar	1 %

This gases are not toxic, but changes in their relative constituents, and particularly oxygen, have an effect on life and combustion processes. Therefore it is essential that the air we breathe should contain sufficient oxygen (> 19 %).

Our senses are incapable of detecting changes in the concentration of the constituents of air sufficiently quickly, since they are odourless and colourless.

#### **2.1.1 Dangers**

The risk of suffocation is high due to normal evaporation of liquid nitrogen to nitrogen gas that displaces oxygen in the inhaled air. For example, under standard temperature and pressure conditions (20° C; 1013 mbar), 1 litre of liquid nitrogen evaporates to 680 litres of nitrogen gas. The critical limit of oxygen can be easily reached. Oxygen deficiency is dangerous and can cause death from suffocation. The reaction of the organism to oxygen deficiency is different from one person to another. It is impossible to give any valid information in general about symptoms of a starting oxygen deficiency.

### **2.1.2 Causes**

To protect yourself from risks of oxygen deficiency pay attention to following points:

- usage of liquid or gaseous nitrogen
- natural evaporation of liquid nitrogen
- refilling of liquid nitrogen
- leaks in storage tanks for liquid or gaseous nitrogen
- defective vent pipes or exhaust pipes
- tipping over the vessel

This list is not complete.

### **2.1.3 Recommendation**

Proceed as follows to prevent the risks of oxygen deficiency:

- keep always the vessel in the vertical position
- close the vessel with an suitable lid
- do not put the vessel in bright sunshine or close to a heat source
- do not transport the vessel by car
- premises must always be well ventilated
- prevent strokes, avoid shocks and sudden movements
- wear always individual protective equipment (suitable gloves, safety goggles or protection visors and closed shoes)
- check the oxygen content continuously
- carry an oxygen meter
- train personnel

This list is not complete.

### **2.1.4 General behaviour to be followed in case of accident**

Proceed as follows:

- mark the environment to prevent secondary accidents
- take action quickly: the rescuer must have taken individual protective measures (independent breathing protection apparatus)
- move the victim(s) away as quickly as possible
- pay attention to internal first aid rules of your plant
- ventilate the room sufficiently
- find out the reason of accident

This list is not complete.

## **2.2 CRYOGENIC BURNS**

Liquid nitrogen is extremely cold (-196° C)

Parts of vessel that have been in contact with liquid nitrogen (especially while refilling) can burn the skin in case of contact.

### **2.2.1 Danger**

Cryogenic fluids can:

- cause burns on the human body
- make materials (metallic or plastic) brittle in case they are not suitable for low temperatures
- cause strong nebulosity, depending on the air humidity of premise

### **2.2.2 Causes**

There are two kinds of cryogenic burns:

#### **2.2.2.1 Burns by splashes**

It is important to protect yourself against the risk of splashes while using liquid nitrogen, especially when handling with samples. Splashes can cause cryogenic burns that can have serious consequences, especially when hitting eyes or face.

#### **2.2.2.2 Contact burns**

Contact between skin and cold materials causes frostbites or cryogenic burns. Never touch or grip the inner side of vessel or samples with a bare hand.

### **2.2.3 Recommendation**

Proceed as follows to prevent the risks of burns:

- prevent skin contact with cryogenic liquids
- never touch the cold walls of vessel, or un-insulated or frosted equipment
- wear individual protection equipment (suitable gloves, safety goggles or protective visors and closed shoes)
- always hold the vessel in the vertical position
- use only suitable equipment (metal or PTFE hose) for refilling the container
- train personnel

This list is not complete.

## **2.2.4 General behaviour to be followed if liquid nitrogen is splashed**

### **2.2.4.1 In the eyes**

- wash the eye with a generous supply of water for at least 15 minutes
- pay attention to internal first aid rules of your plant
- consult a doctor

### **2.2.4.2 On the skin**

- do not rub
- if possible, remove or loosen your cloths
- defrost affected parts by moderate and progressive heating
- do not apply anything on the burned area
- pay attention to internal first aid rules of your plant
- consult a doctor

Both lists are not complete.

## **2.3 THE RISK OF EXPLOSION**

### **2.3.1 Dangers**

The evaporation of liquid nitrogen can causes an overpressure inside of the vessels.

### **2.3.2 Causes**

The increase of pressure in the vessel may happen due to:

- poor maintenance of the container
- accumulation of ice on the neck and the lid

This list is not complete.

### **2.3.3 Recommendation**

Proceed as follows to prevent the risk of explosion:

- always use a suitable lid (pay attention to an exhaust gas opening)
- respect filling levels to prevent the formation of ice on the lid
- use the vessel only in dry and sheltered locations
- control the humidity of the room
- check vessel periodically with regards to accumulations of condensation water
- check vessel periodically with regards to surface defects and material damages

This list is not complete.

### **2.3.4 General behaviour to be followed in case of accidents**

Please see above under 2.1.4, oxygen deficiency.

## **2.4 OXYGEN ENRICHMENT**

### **2.4.1 Dangers**

Oxygen enrichment can enlarge the risk of explosion or fire.

### **2.4.2 Causes**

Oxygen enrichment, as a result of liquefaction of ambient air, can occur, because the boiling point of oxygen is high (-183° C) than the boiling point of liquid nitrogen (-196° C).

### **2.4.3 Recommendation**

Proceed as follows to prevent the risk of explosion in case of oxygen enrichment:

- do not smoke
- eliminate easily inflammable products from the area of vessel, if possible
- eliminate all sources of fire (flames, sparks, matches, lighters, etc.)
- premise of vessel must be continuously and adequate ventilated
- clean the floor regularly
- train personnel
- wear individual protection equipment
- check the oxygen content continuously
- always wear an oxygen meter

This list is not complete.

## **2.5 ENVIRONMENT OF VESSEL**

### **2.5.1 The premise**

The premise of vessel shall:

- enable safe operation for participants
- enable a safe refilling of vessel
- be continuously and adequate ventilated
- have a flat and non-porous floor, capable of resisting the maximum load of vessel
- include posters (safety data sheets) mentioning the dangerous properties of liquid nitrogen
- prevent access to unauthorised persons
- enable a good accessibility of vessel for inspection, cleaning and maintenance

This list is not complete.

## **Kaltgas System for direct gas cooling**

The Kaltgas System Type TG-LKF-H KFNW25 is a high-performing cooling system for tempering by means of a cold gas flow. The high cooling performance of the system is based on the cooling capacity of liquid nitrogen.

## **2. Function and description of plant**

Liquid nitrogen is heated in a LN2 storage tank by means of a vaporizer (JET). The cryogenic gas flow is then piped through a vacuum insulated pipe to the gas outlet nozzle. The vacuum insulated pipe is equipped with a heat exchanger (HEATER) which heats the cold nitrogen gas to the temperature set on the controller. The temperature sensor (PT100) installed downstream of the heat exchanger measures the temperature in the gas flow before the gas enters the gas outlet nozzle. The capacity of the vaporizer (JET) determines the cooling capacity while the capacity of the heat exchanger (HEATER) determines how much the gas is heated up. At the gas outlet nozzle, a temperature-controlled gas flow is available which can be kept stable up to a temperature of a max. of  $-170^{\circ}\text{C}$ . The lowest temperature achievable is approximately  $-180^{\circ}\text{C}$  with the JET running at 100% capacity and the highest temperature achievable is  $100^{\circ}\text{C}$  with the JET running at 30% capacity

The high insulation capacity in the system is obtained by using vacuum insulated components which significantly reduce the heat impact of the ambient temperature on the cold gas flow. The insulation vacuum required is generated by a vacuum pump. The vacuum connection between the pump and the cold gas line is realized by a flexible corrugated hose and a vacuum valve.

## **3. Unpacking and initial inspection**

Please unpack all parts carefully and check them for damage. It is important that any transport damage be detected when the parts are unpacked. Any defects / damage must be documented immediately. Please inform the manufacturer.

- For the permissible ambient conditions, refer to the technical data of the temperature controller.
- Before commissioning the plant, check if your mains voltage is 230V ~ 50 Hz.
- Please comply with the safety instructions for liquid nitrogen.

## 4. Components of Kaltgas System Type TG-LKF-H

- LN2 siphon  
equipped with:
  - small flange NW 50 for connection to storage tank
  - vaporizer ( JET -500W) length 1200mm
  - Alu vaporizer standard
  
- cold gas line,  
equipped with:
  - suitable for vacuum insulation
  - temperature sensor PT 100
  - heating element with heat exchanger (HEATER-630W) and KF NW 25 / 80
  
- safety controller SC5
  - connection for heater
  - connection for vaporizer (Jet)
  - type **Jumo dTron 316** with 2 x PT 100
  
- converter
  - interface, converter USB (and software free of charge)
  
- temperature sensor PT 100 external
  - temperature sensor L=460mm / D=1.6mm
  
- electrical connections
  - connecting cables
  - safety controller vaporizer ( JET )
  - connection cable (grey) safety controller heater
  - connecting cable (white)
  - connecting cable Heater (red)
  - connecting cable Heater (black)
  - connecting cable USB
  - mains cable 230V
  
- vacuum pump
  - Vacuum pump RZ 6 with accessories and corrugated connecting hose
  
- LN2 tank
  - 50 litre LN2 storage tank Type Apollo

# 5. Installation

In order to ensure a smooth operation of the Kaltgas System, please install the system in the given order.

- 1. Fix and secure cold gas line to object to be cooled. Provide a strain relief, if necessary.

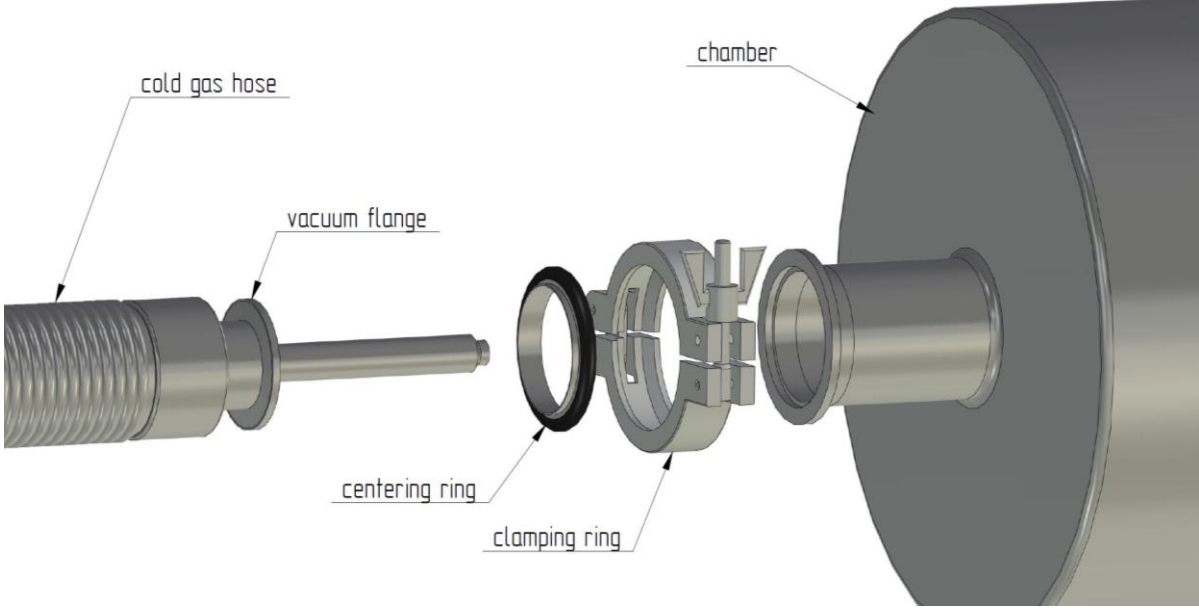

- 2. Using the corrugated hose to connect the cold gas line to the vacuum pump and using the vacuum pump, evacuate the cold gas line for at least 20 minutes before the start of the work.

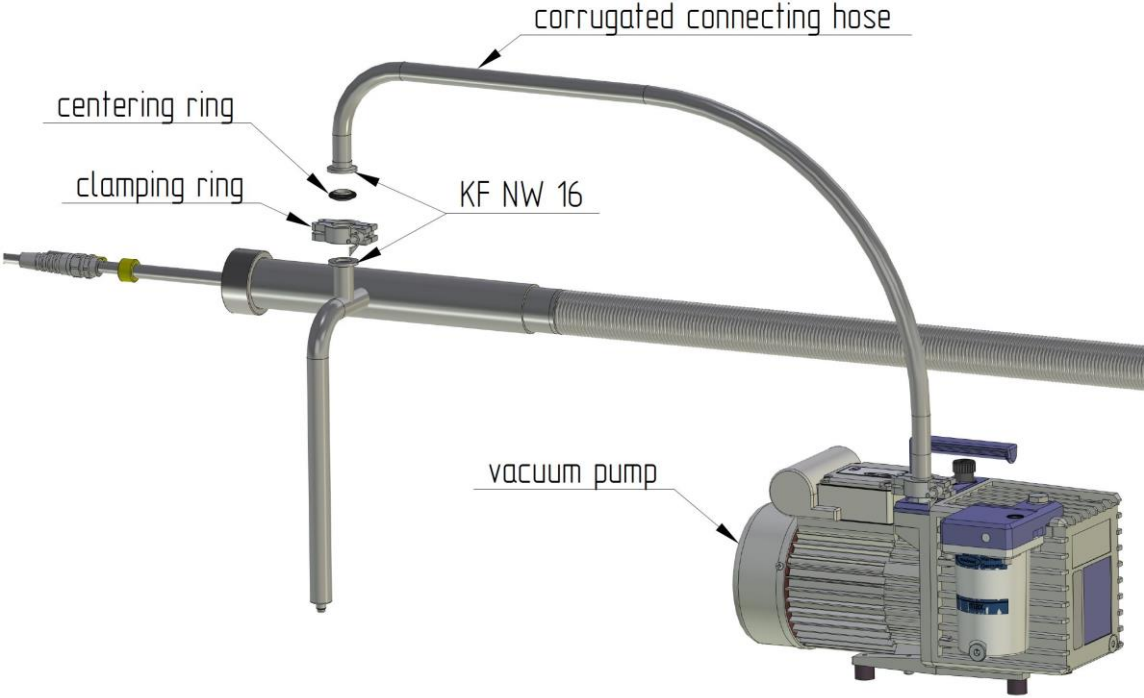

3. Install LN2 storage tank at place of installation.

4. Place the centering and O-ring over the LN2 evaporator and place the JET "slowly" into the LN2 tank, otherwise LN2 may spurt out of the vessel in an uncontrolled manner. Secure lifter with clamping ring.

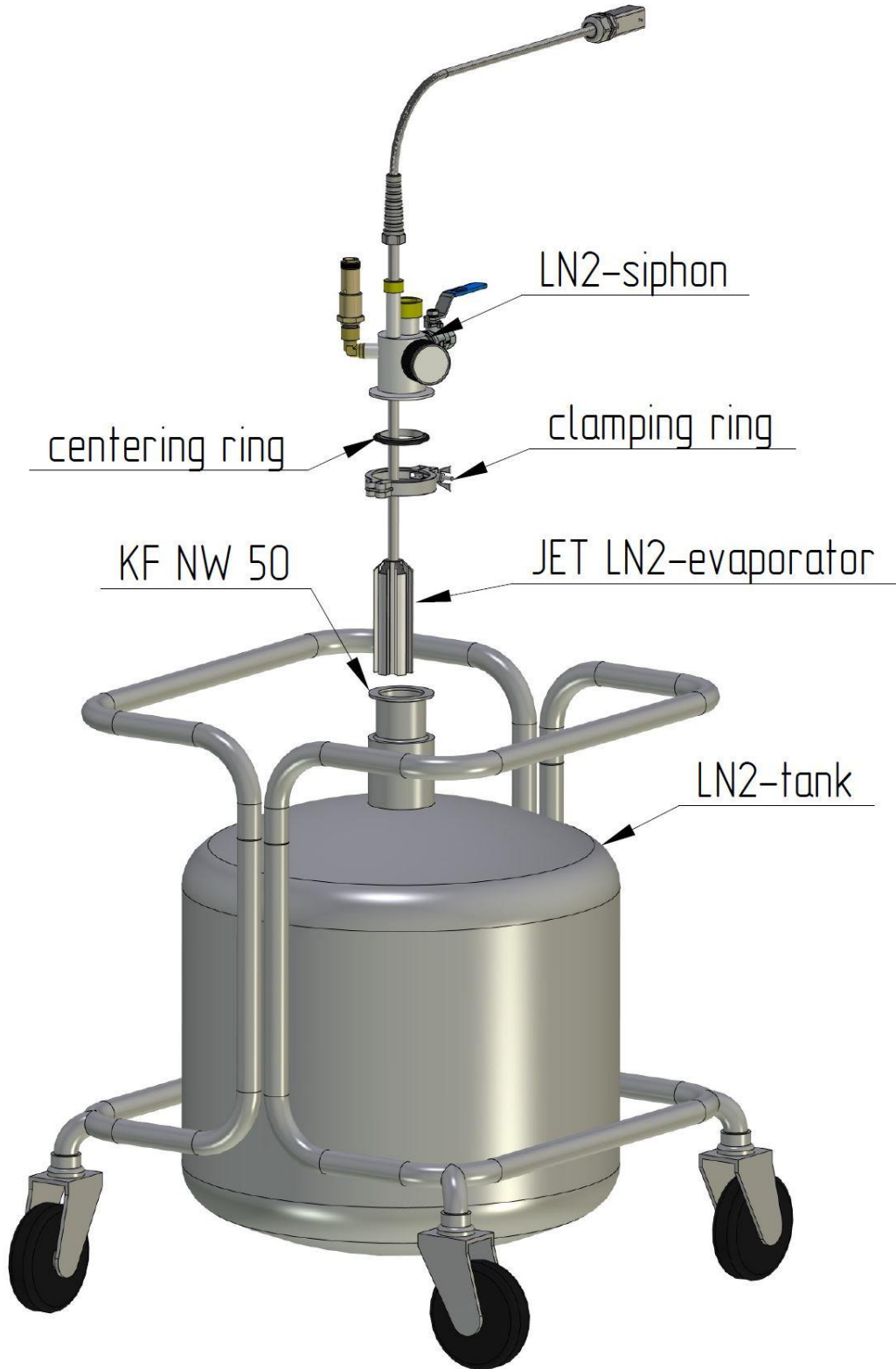

5. Insert cold gas line in squeeze connection of siphon and secure it.



6. Electrical connection

- a. vaporizer (Jet) - extension cable **grey** - safety controller (Jet)
- b. cold gas line (heater) - extension cable **white** - safety controller (heater)
- c. temperature sensor Heater – extension cable Kaltgas **red**
- d. temperature sensor chamber – extension cable Kaltgas **black**
  
- e. vacuum pump - mains (mains plug 230V)
- f. safety controller - mains (mains plug 230V)
- g. connected safety controller with converter
- h. connected the converter USB to your computer

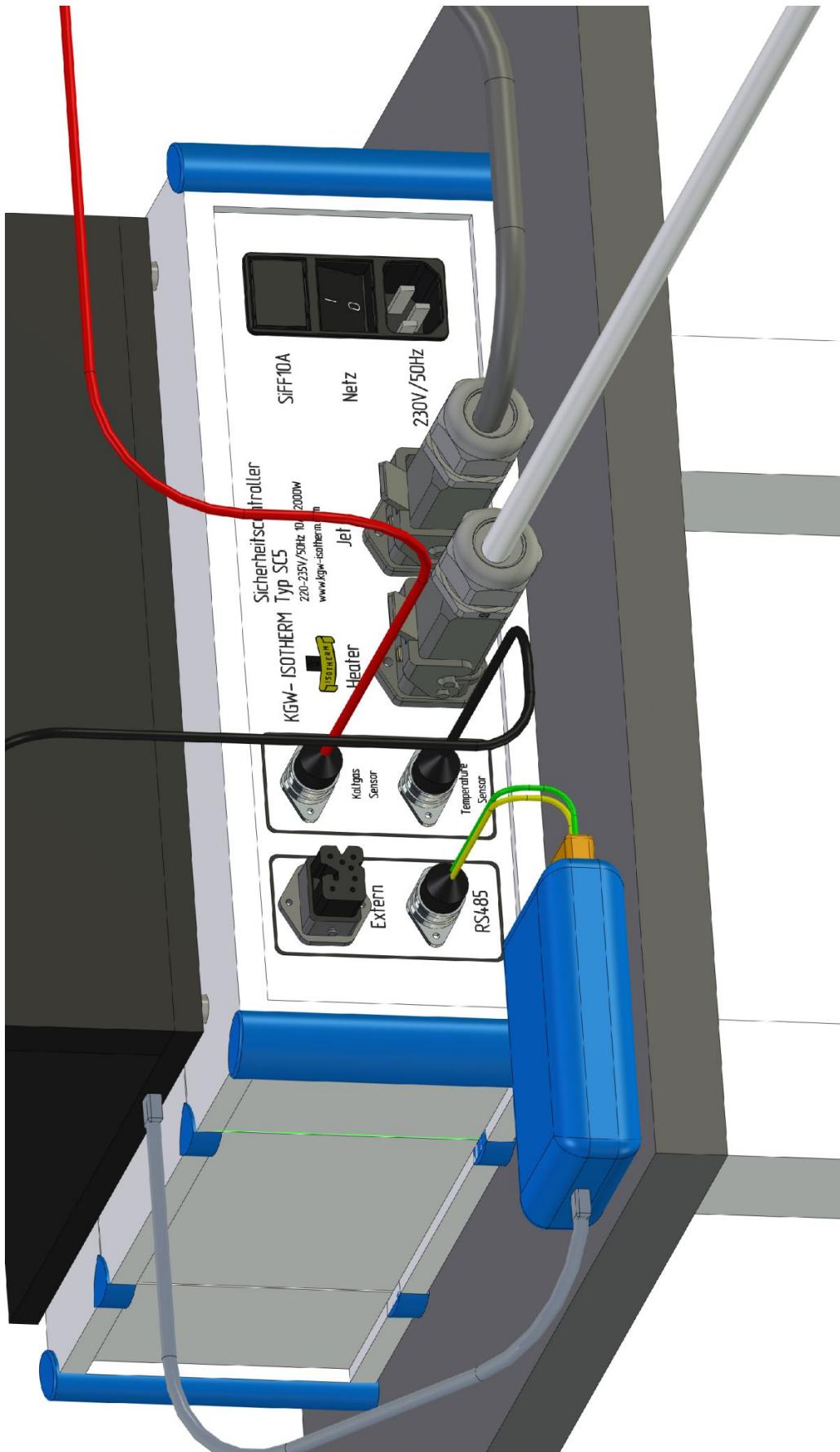

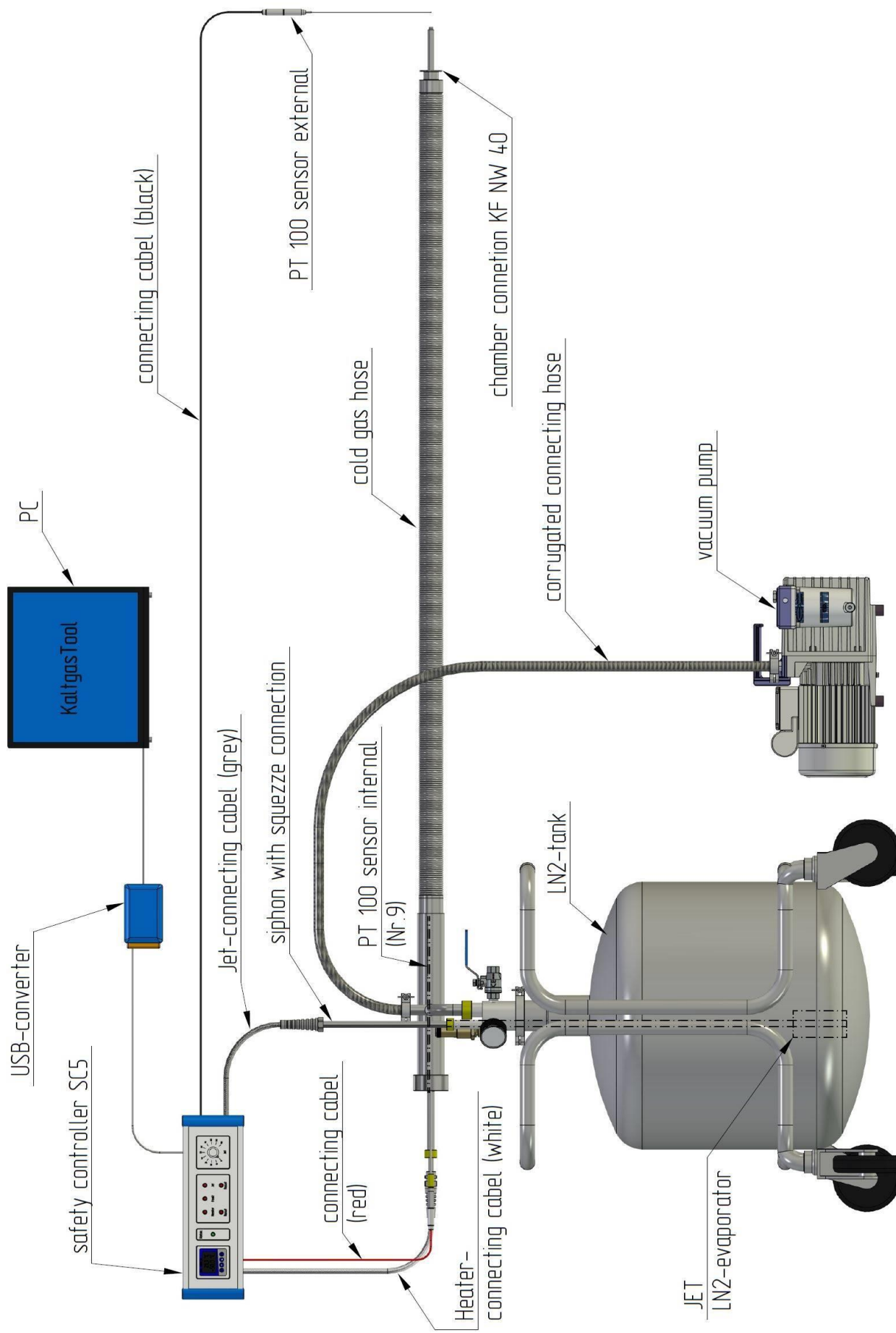

## 6. Handling and function of safety controller

### 6.1 Layout - rear

- a) Connect the LN2 vaporizer (JET) to the corresponding socket on the safety controller, grey connecting cable.

Connect the heat exchanger (Heater) to the corresponding socket on the safety controller, white connecting cable.

- b) Connect the red connection cable to the internal temperature sensor (cold gas hose) to the upper Renk socket KALTGAS SENSOR.
- c) Connect the red connection cable to the external temperature sensor (chamber sensor) to the lower Renk socket TEMPERATURE SENSOR.

Caution Important: Do not interchange the two cables.

- d) Connect the plug of the USB converter to the RS 485 socket.

- e) If required, connect the separate alarm output.

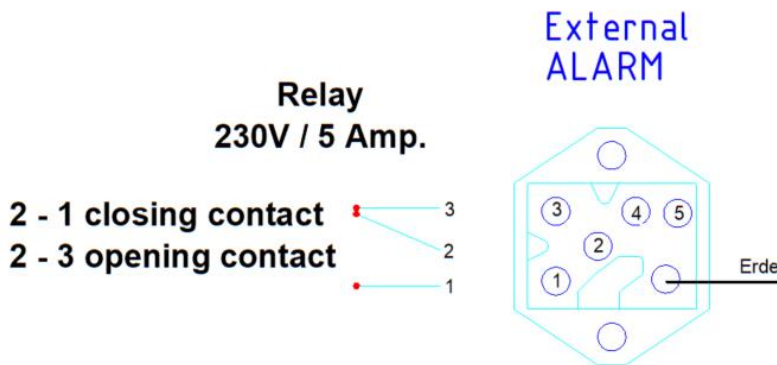

- f) Connect the mains cable.

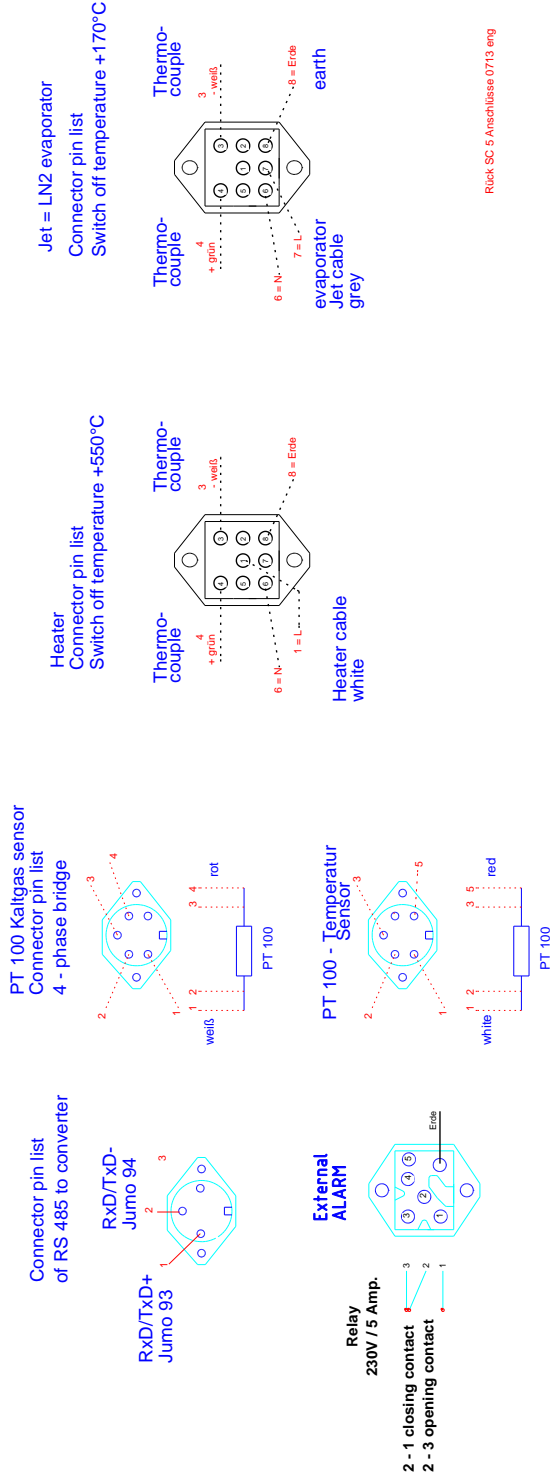
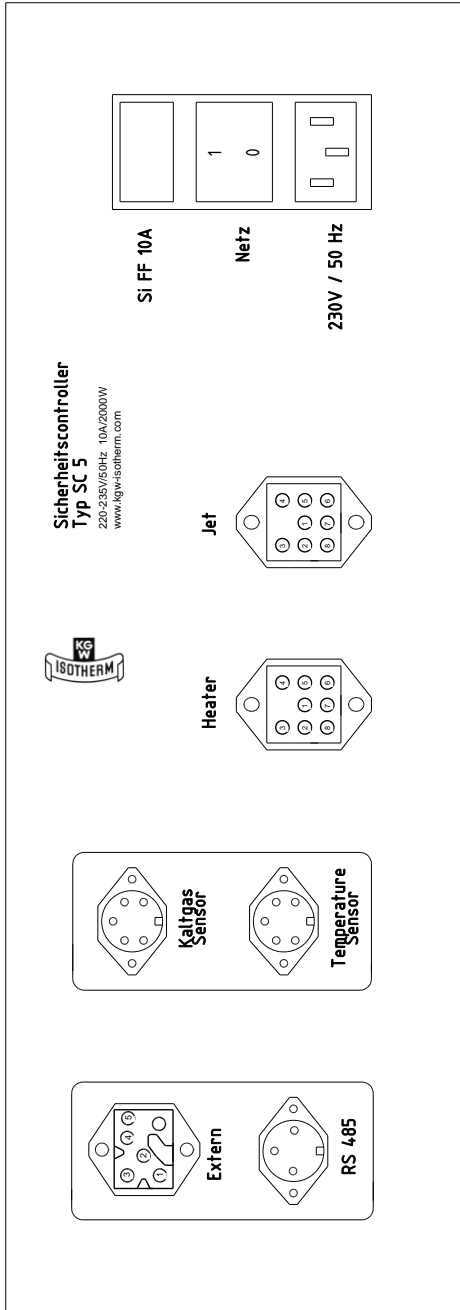

## 6.2 Layout - front

- a) Power controller for LN2 vaporizer 0 - 100%. When turning the safety controller on, set the LN2 vaporizer to 0%, to avoid that the jet does not evaporate directly after activation of the LN2.
- b) Temperature controller Type JUMO dtron 316 with actual value and required value display. **After a cooling process, always set the controller to a temperature below the actual value so that the heater does not start heating immediately when the system is switched on.**
- c) Safety switch ( Heater and Jet )
- d) As soon as all electrical cables have been connected, the plant has been installed and liquid nitrogen is in the LN2 tank, the safety controller can be switched on. Ensure that the power controller (Jet) is set to 0 and the temperature controller is set to a value below the actual value.
- e) When the safety controllers are switched on, the lamps Heater-Fault-Jet will be on. Now, the safety circuit is activated manually by pressing the button.
  - 1) Press JET pushbutton. ( lamp JET is off)
  - 2) Press HEATER pushbutton. ( lamp HEATER is off)Fault safety control indicator must be off.

Now, the safety controller is active, by turning the power controller (0 - 100%) you can generate a N2 gas flow for cooling.

**All tests were done with a 50% jet setting.**

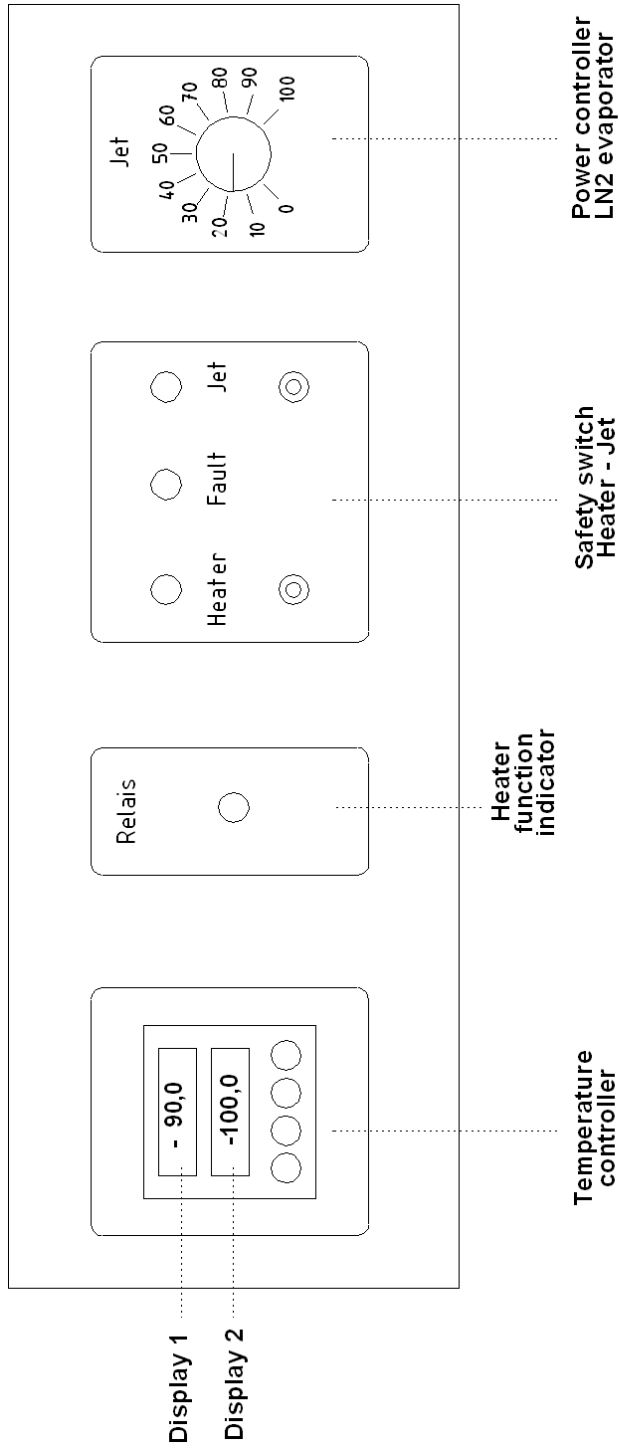
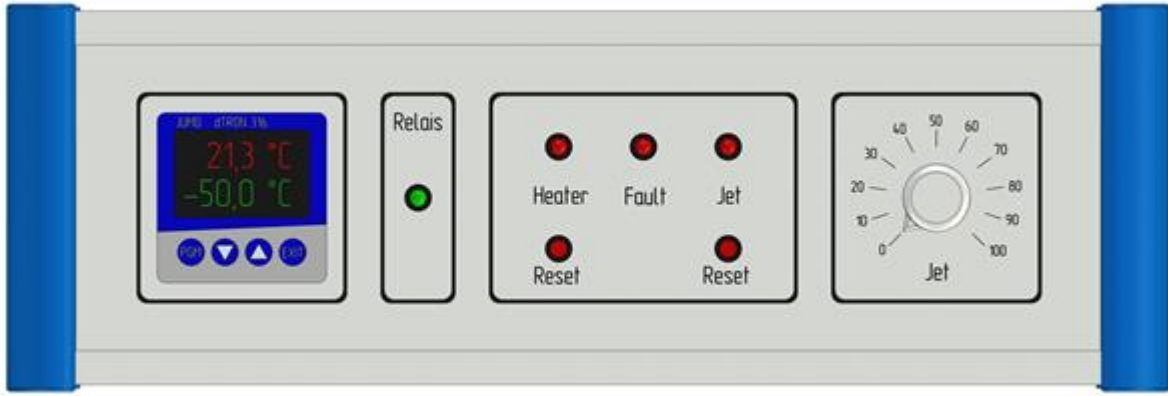

Display 1 = Actual control sensor Heater (cold gas sensor)  
 Display 2 = Actual temperature sensor (chamber sensor)

## 7. Commissioning of LN2 tank Type Apollo with LN2

**Important: Wear safety gloves, goggles.**

Please comply with the operating instructions supplied with the tank. In addition comply with the applicable BG, GGVSE / ADR and internal directives.

**Important: In the case of small, insufficiently ventilated rooms, an oxygen measuring instrument with warning signal must be used.**

7.1 The tank is delivered in original condition with the LN2 tapping siphon in place.

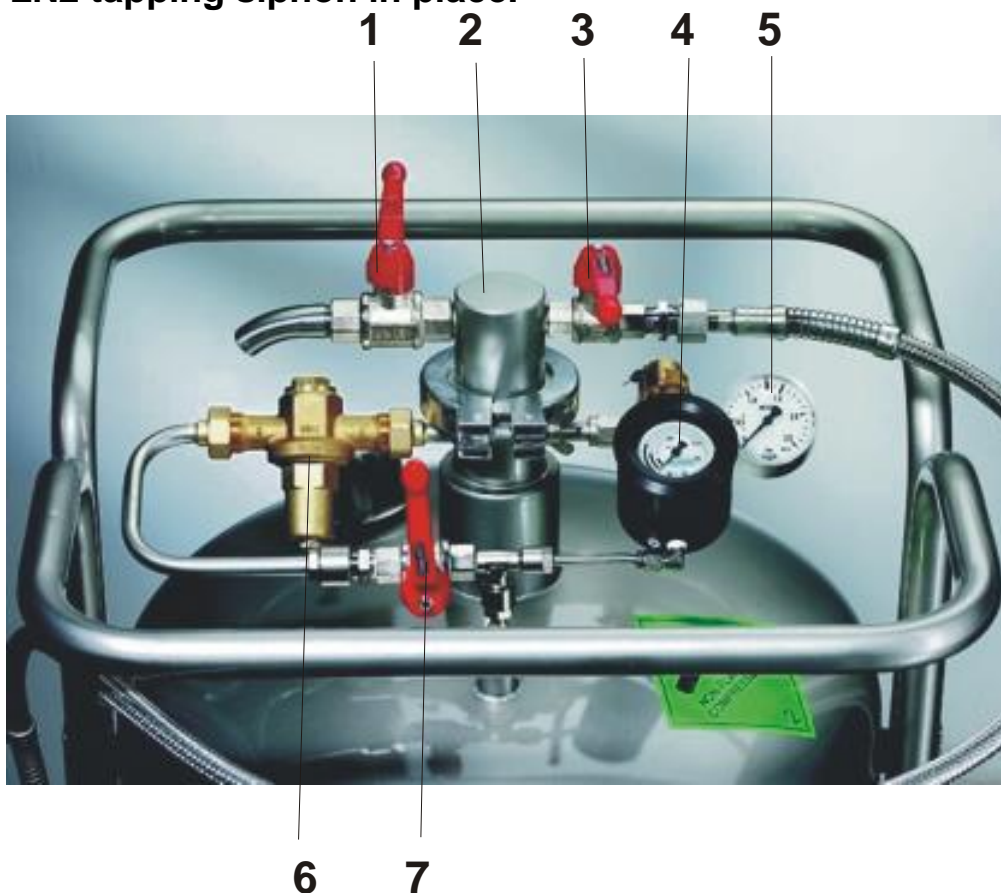

**Important: When handling LN2, always wear safety gloves and goggles.**

- a) Open pressure relief valve (no. 1) in order to allow any overpressure that may be present in the tank to escape.
- b) Open quick-acting fastener on siphon (no. 2) and pull siphon out of tank. The metal hose on the siphon is removed, too.
- c) Pressure build-up controller, if installed, must not be manipulated by the user. Any modifications or settings may only be performed by the manufacturer or trained staff.
- d) Pressure build-up valve (no. 7) is always closed when used with the Kaltgas System. If the pressure build-up valve (no. 7) were opened, an uncontrolled gas flow would be generated. Temperature-stable control of such a gas flow would not be possible.
- e) The LN2 tank Apollo is brought to the LN2 filling station without the siphon. In order to prevent penetration of atmospheric moisture, the supplied loose sealing plug is fixed to the tank neck (KF NW 50).
- f) After the tank has been filled with LN2, it is transferred to the Kaltgas System, and the LN2 vaporizer (Jet) is inserted in the tank slowly.
- g) When the LN2 vaporizer is inserted, increased gas generation occurs in the cooling phase of the aluminium heat exchanger and the heating element. This may cause an overflow of LN2.

**In order to prevent the LN2 from spilling, the LN2 vaporizer must be inserted slowly ( takes approx. 2 minutes)**

## 8. Commissioning of Kaltgas System

The cold gas hose is equipped with a locking mechanism both on the gas input and the gas output side. The two locking mechanisms prevent moisture from penetrating the hose. Any moisture in the cold gas hose might result in the formation of ice droplets during commissioning of the Kaltgas System and clog the cold gas hose so that the cold nitrogen gas can no longer flow through the line. This would result in overpressure in the vaporizer Dewar and opening of the 0.5 bar valve.

Closing the cold gas hose is particularly important after a cooling process. After a tempering process, the whole hose interior has cooled down so much that the moisture from the ambient air would condense in the hose immediately, which would result in significant formation of condensation water and the risk of ice forming in the hose.

To avoid this, the order of closing the cold gas hose specified here must be kept in any case.

After a cooling process, set the Jet (LN2 vaporizer) to 0, then wait until no more gas escapes from the cold gas nozzle. Open the pressure relief valve on the siphon. Next, close the cold gas nozzle using the supplied locking mechanism to prevent penetration of condensation water or the formation of ice in the gas outlet area. Then pull out the cold gas hose from the vaporizer Dewar (squeeze connection siphon) and protect it against penetration of condensation water using the sealing socket. The overpressure forming as a result of the heating of the gas in the cold gas hose can escape through the valve provided at the sealing plug. The locking mechanisms remain at the hose until the next cooling operation.

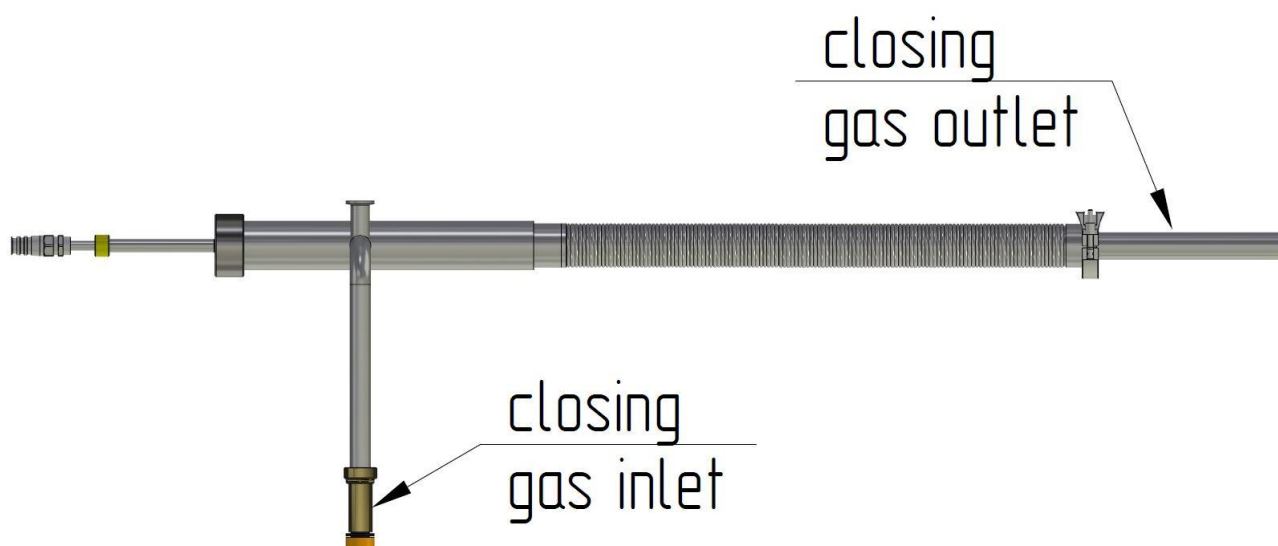

Before commissioning the Kaltgas System, read the Jumo controller operating instructions and follow the instructions on the safety controller. For commissioning, proceed as follows:

1. Switch on vacuum pump and wait for 20 minutes until the required vacuum is reached.
2. Remove cold gas line from siphon and open N2 valve on siphon.
3. Take off the siphon with the LN2 vaporizer Jet from the storage tank and fill the tank with liquid nitrogen (LN2).
4. Place centring and O-ring Ring NW 50 on the tank flange and immerse the vaporizer in LN2 carefully. The vaporizer should have a distance of 1-2 cm from the bottom of the LN2 tank.

**Warning!! Immerse the vaporizer in liquid nitrogen slowly !  
Due to high gas formation during immersion, LN2  
may spill out.**

**Important: Wear safety gloves, goggles.**

5. Place siphon on tank flange and secure with fastening ring.
6. Insert and lock cold gas line in squeeze connection.

**Warning: Cold gas line must not be immersed in liquid nitrogen !**

7. Close exhaust gas valve.  
During operation, always ensure that the pressure indicated by the manometer does not exceed 0.2 bar ( if necessary, stop cooling operation because the cold gas line may be clogged by ice).
8. Switch on safety controller with temperature controller.

9. Set evaporator power to required value.

**( Optimal for this system is 50% JET )**

**Or easier to control via the "KaltgasTool" software**

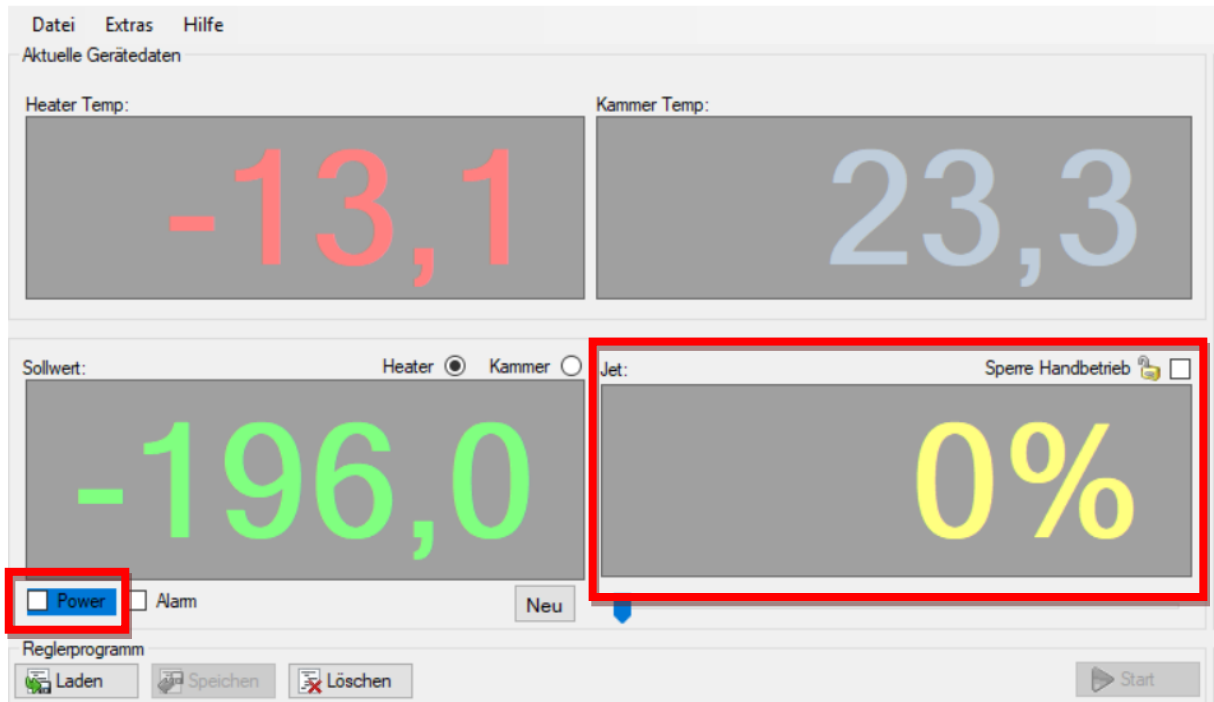

Here, care must be taken that before any adjustments are made to the JET or the set point temperature, the hook at power is removed, in order to avoid an unwanted start of the system. If the hook is removed, the settings can be changed without risk to the user and the system. If the settings have been changed, the hook must be set again to start the system.

For easier handling of the cold gas system, the cold gas software is available. The exact functionalities of the software can be found in the **Kaltgas Software Manual**.

## 9. Operating settings

### Attention very important

### It is essential to follow the procedure when switching on the safety controller

A) Your cold gas assembly is completely wired and all components are connected to the safety controller.

B) Turn on the safety controller via the power switch which is on the back panel.

C) The three signal lamps of the safety distance light up. Before activating the safety plug via the REST switches, set the JET knob to 0% and check whether the setpoint on the temperature control is set to a negative value (eg  $-40\text{ }^{\circ}\text{C}$ ). If the temperature controller has a positive temperature at setpoint, the heater's heater would immediately heat up to full power after the REST.

D) After checking the setpoint to a minus temperature and the setting of the JET Controller to 0%, you can activate the safety distance via the reset buttons.

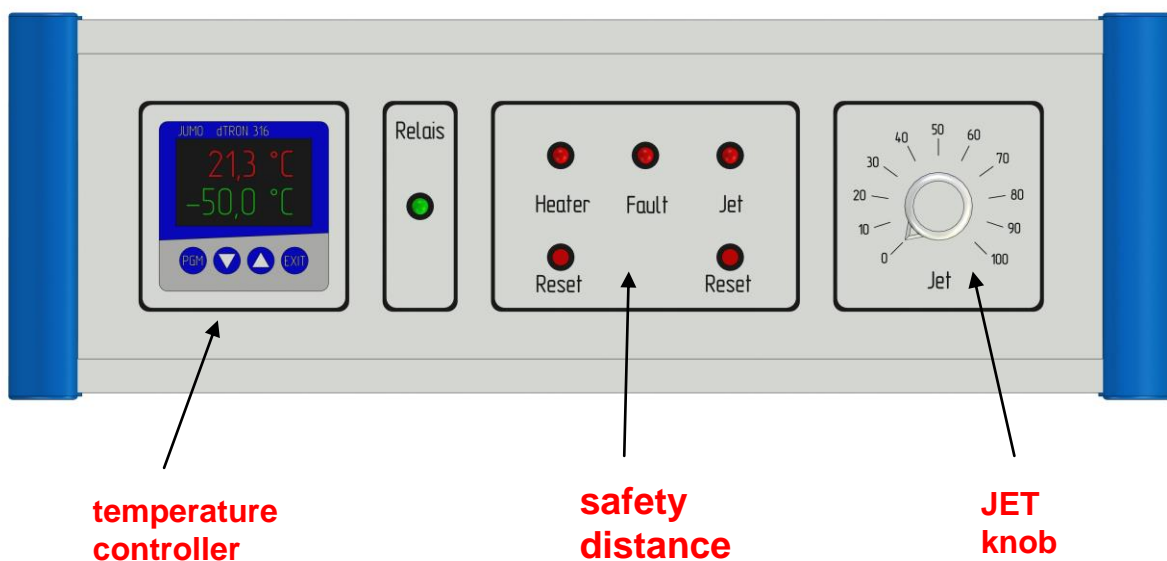

## **9.1 Standard operating settings of temperature controller Jumo dTron 316**

The temperature controller was configured with its default operating settings. These standard operating settings are saved in the sample software. If the parameters of the default operating settings were changed, whether intentionally or unintentionally, the standard configuration of the controller can be restored quickly and easily via the software (in "device setup").

## **9.2 Operating settings temperature controller Jumo dTron 316**

- a) temperature sensor PT 100
- g) setting range from -196°C to +100°C

## **9.3 Connecting the temperature sensors to Jumo controller**

This safety controller features two PT 100 ports.

The upper port is for temperature control ( cold gas sensor ). This port is for the temperature sensor installed in the cold gas hose and controlling the gas flow temperature. ( Jumo controller display 1)

The second connection is for external temperature display (Temperature Sensor). This temperature sensor is only used for display of an external gas or room temperature (tempering chamber). ( Jumo controller display 2)

## **9.4 Quick Set-up of Jumo controller**

First complete Section 4 (installation)

- a) Switch controller on and set JET power to 50% ;
- b) Switch on temperature controller on mains switch;
- c) Adjust required temperature value :
  - 1) By pressing arrow buttons  $\Delta$  and  $\nabla$  adjust the required value. The required temperature value is displayed on the controller on display 2 (bottom). When you are finished with setting the required value, display 2 will return to displaying the temperature measured by the sensor.
  - 2) After 2 seconds, the required value is taken over automatically and the temperature controller starts to control the temperature.

d) Start self-optimization of temperature controller :

- 1) Press buttons  $\Delta$  and  $\nabla$  simultaneously for approx. 3 seconds ;
- 2) On the screen, 'tune' will be displayed, self-optimization is started;
- 3) When 'tune' is no longer flashing, the self-optimization process is complete ;
- 4) Then, the self-optimization must be confirmed by pressing the EXIT button.

In order to obtain optimum temperature stability, the self-optimization process must be carried out separately if the required temperature value and / or the Jet power are changed.

( A self-optimization carried out at  $-80^{\circ}\text{C}$  can be used for most temperatures.)

**Self-optimization at  $-80^{\circ}\text{C}$  has already been carried out.**

## 9.5 Operating settings on safety controller

In order to avoid constant operation of the Kaltgas System at full load, we recommend using the following operating settings:

maximum heating rate:	5 K / minute
maximum vaporizer power (Jet) during cooling without temperature control:	90 %
maximum vaporizer power (Jet) during cooling with temperature control:	50 %
optimum heating power (Heater) in continuous operation:	approx. 40%

**Basic settings for cooling to  $-90^{\circ}\text{C}$ , for example.**

### Variant 1 Quick cooling followed by LN2 optimization

Set Jet to 80 % power and cool your installation to a temperature of approx.  $-80^{\circ}\text{C}$ . Then reduce the jet power to 50% and allow installation to cool down in a temperature-controlled manner to  $-90^{\circ}\text{C}$ . With this jet power settings, you can operate the installation. If you want to reduce the LN2 consumption as soon as the working temperature of  $-90^{\circ}\text{C}$  is reached, reduce the jet power in 5% steps until a low heating power of approx. 30 % (heater on time) is obtained. Thus, you have determined the lowest LN2 consumption for your application.

## **Variant 2**    Temperature-controlled cooling followed by LN2 optimization

Set the Jet power to approx. 50% and allow the installation to temper to -90°C without manual intervention. With this setting, the system can operate automatically. If you want to reduce the LN2 consumption as soon as the working temperature of -90°C is reached, reduce the jet power in 5% steps until a low heating power of approx. 30 % (heater on time) is obtained. Thus, you have determined the lowest LN2 consumption for your application.

### **Heating**

Set the Jet to approx. 40% power and heat up your installation to a temperature of approx. +20°C at a heating rate of approx. 5°C per minutes.

**Important for heating or warming: !! You must use the internal (installed) sensor for temperature control !!**

### **!!! Caution - very important !!!**

When using a temperature sensor in the chamber, the dead time of the control system must be taken into account, otherwise the Kaltgas System might be damaged. The internal sensor of the Kaltgas System must be used for heating.

### **!! IMPORTANT !!**

The Kaltgas System can also reach higher heating rates at a reduced gas flow. This would result in a very high mechanical and thermal load on the heat exchanger and would reduce its useful life.

### **!! IMPORTANT !!**

All heaters feature an integrated thermo element which is to protect the safety temperature monitoring system of the heating element against overheating.

**Safety shut-down temperature Jet : max. +170°C**

**Safety shut-down temperature Heater : max. + 550°C**

### **Warning:**

Upon completion of the cooling operation please leave the exhaust gas valve of the siphon closed to enable the nitrogen-gas produced by self-evaporation to escape through the cold gas line and to avoid icing inside the line.

Directly after disconnection of the cold gas hose from the LN2 tank, the gas openings must be closed with the supplied locking mechanisms to prevent condensation water from entering the hose.

## 9.5 Very important setting data

The cold gas plant is an open temperature control system that can cover very large temperature ranges. However, a cold gas system always remains a low temperature system and must be used as such. Depending on the capacity of the jet, the heating capacity can reach its limits at higher temperatures and the heater can therefore no longer heat the gas flow sufficiently. In such a case, the heater heats continuously (see green lamp on the control unit) and can therefore destroy the fit between the heating element and the heat exchanger in the long term. For this reason we have listed some setting data for you.

Power Jet = 500 Watt and Heater = 630 Watt.

- a. Cooling without control can take place at full power.
- b. Adjusting at  $-170^{\circ}\text{C}$  approx. 80% jet.
- c. Adjusting at  $-150^{\circ}\text{C}$  approx. 70% jet.
- d. Adjusting at  $-100^{\circ}\text{C}$  approx. 50% jet.
- e. Adjustment at  $-50^{\circ}\text{C}$  approx. 50% jet.
- f. Adjustment between  $-50$  and  $+10^{\circ}\text{C}$  approx. 50% jet.
- g. Adjusting at  $+20^{\circ}\text{C}$  approx. 40% jet.
- h. Temperatures above  $+20^{\circ}\text{C}$  approx. 40% jet
- i. Temperatures at  $+80^{\circ}\text{C}$  approx. 40% jet.

### Caution:

Cooling with the cold gas system is unproblematic for the entire structure, since no large temperature loads on the heater come. Heating from a low temperature to a higher temperature, or to room temperature and above, is a very heavy burden on the heat exchanger and must be slow and gradual. For this, a programming point (room temperature) is available in the software.

The cold gas software is available for easier handling of the cold gas system.

## 10. Safety instructions

- Plant must always be supervised during operation!
- Plant may be commissioned only if sufficient liquid nitrogen is in the nitrogen storage tank !
- Work on the controller may only be carried out by qualified technical staff
- Energized parts must be protected against dust, moisture, impact, overheating
- Follow safety instructions when handling liquid nitrogen, refer to
- EC safety data sheet according to TRGS 220 by AIR LIQUIDE dated 29 August 2002  
(Wear safety goggles and gloves) !
- Containers filled with liquid nitrogen must not be sealed gastight if no safety valve is provided.
- Follow safety instructions of supplied operating instructions!
- After operation, keep exhaust gas valve closed!
- Before stopping vacuum pump, close vacuum valve!

## 11. Maintenance and cleaning

Disconnect all devices from power supply. The temperature controller and the safety controller generally do not require any maintenance. If these components need repair, they may only be opened by the manufacturer.

All live components may only be cleaned with a dry cloth. Make sure that no water enters the inside of the devices.

## 12. Troubleshooting

Normally, the system should work trouble-free. If a fault occurs, please follow the following troubleshooting program.

Identified defect	Possible cause	Repair of defect
Controller-specific defect		- Jumo manual
No tempering gas comes out of the cold gas nozzle	<ul style="list-style-type: none"> <li>- Jet out of service</li> <li>- exhaust gas valve open</li> <li>- vaporizer defective</li> <li>- interior of cold gas line iced</li> <li>pressure in tank &gt; 0.3 bar</li> </ul>	<ul style="list-style-type: none"> <li>- start Jet.</li> <li>- close exhaust gas valve.</li> <li>- check vaporizer resistance. The resistance betw. Pin 1 and Pin 3 must be approx. 100,2 Ohm ! have Jet replaced, if necessary.</li> <li>- shut down system, open exhaust gas valve, allow cold gas line to thaw and purge moisture with hot nitrogen gas.</li> </ul>
Gas temperature drops continuously	<ul style="list-style-type: none"> <li>- heater defective</li> </ul>	<ul style="list-style-type: none"> <li>- check heater resistance. Resistance betw. Pin 1 and Pin 2 must be approx. 81,4 Ohm ! have heater replaced, if necessary.</li> </ul>
Cold gas hose iced	<ul style="list-style-type: none"> <li>- vacuum pump defective</li> <li>- cold gas hose - vacuum leak</li> </ul>	<ul style="list-style-type: none"> <li>- check pump using vacuum measuring instrument</li> <li>- carry out He leak test on cold gas hose</li> </ul>

## 13. Technical Specifications

### 13.1 Safety controller

Mains voltage	: 230V ~ 50 Hz.
Connections	: - JET (Harting 7 D) - HEATER (Harting 7 D) - Temperature controller (diode connector - Renk)
Permissible ambient conditions	: 10 to 50°C, max. 75% rel. moisture

### 13.2 Temperature sensor

Type	: PT 100 encapsulated
Resistance at 20°C	: approx. 110 Ω
Length / diameter	: 460mm / 1.6mm
Connection	: Male diode connector Renk lock Type71, Type C 3 pin
Connecting cable Kaltgas	: red Kaltgas hose-Heater
Connecting cable chamber	: black external sensor chamber

### 13.3 Jet 500Watt /

#### extension cable grey

Power supply	: 230V ~ 50 Hz;
Heating element, Ø x length	: 12.5 x 1200 mm / approx. 100,2 Ohm
Connection	: Stas5 male connector
NiCr-Ni at 20°C	: 10,4 Ohm

### 13.4 Heater 630 Watt /

#### extension cable white

Power supply	: 230V ~ 50 Hz;
Heating element, Ø x length	: 10 x 450 mm / approx. 81,4 Ohm
Connection	: Stas5 male connector
NiCr-Ni at 20°C	: 5,5 Ohm

#### 13.5.1 Nitrogen consumption at 500 Watt :

Minimum (at $P_{\text{Jet}} = 10\%$ )	: approx. 1 L/h
Maximum (at $P_{\text{Jet}} = 100\%$ )	: approx. 11 L/h

## 14. Warranty

We provide a 12-months warranty, provided that the equipment is handled properly. The warranty cover shall not exceed the purchase value of the equipment. In the case of warranty claims, please contact the manufacturer.

**Prüfblatt Kaltgas Jet / LS. Nr.:**

Kapitel 10

Formular 10/2TG-RD

Ausgabedatum: 19. Jan. 1998

**Heizer für LN2-Verdampfer, Jet**

Länge: 1200 mm

Leistung: 500 Watt / 230 Volt / 50Hz

**Heizstab- und Thermoelementdaten**

Thermoelement: -0,17 mV bei Raumtemperatur

Thermoelement: 10,4 Ohm bei Raumtemperatur

Heizer: 100,2 Ohm bei Raumtemperatur

Raumtemperatur 22 °C

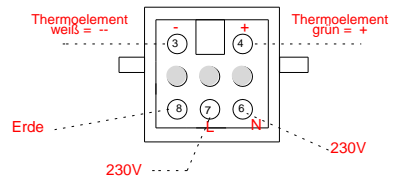

**Elektrischer Kontakt zwischen Heizer und Thermoelement**

Kontakt  ja  nein

**Durchgangsprüfung der Erdung zwischen:**

Erde Mantel  ja  nein

Erde Heizer  ja  nein

Erde Thermolement  ja  nein

Geprüft durch: M.Schieder

Datum: 18.02.2019

**Nummer des Heizstabes:**

**Heberkopf für Jet Kaltgas Vakuumschlauch**

0,5bar Sicherheitsventil  ja  nein

Manometer  ja  nein

Abgashahn  ja  nein

Geprüft durch: Herr Martini

Datum: 13.02.2019

**Prüfblatt Kaltgas Heater LS. Nr.**

Kapitel 10

Formular 10/2TG-RD

Ausgabedatum: 19 Jan. 1998

**Heizer für LN2-Verdampfer, Heater**

Länge: 450 mm

Leistung: 630 Watt / 230 Volt / 50Hz

**Heizstab- und Thermoelementdaten**

Thermoelement: -0,02 mV bei Raumtemperatur

Thermoelement: 5,5 Ohm bei Raumtemperatur

Heizer: 81,4 Ohm bei Raumtemperatur

Raumtemperatur 22 °C

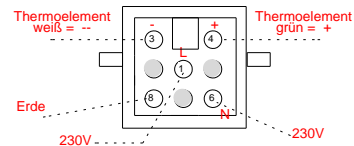

**Elektrischer Kontakt zwischen Heizer und Thermoelement**

Kontakt  ja  nein

**Durchgangsprüfung der Erdung zwischen:**

Erde Mantel  ja  nein

Erde Heizer  ja  nein

Erde Thermolement  ja  nein

Geprüft durch: Herr Schieder

Datum: 18.02.2019

**Nummer des Heizstabes:**

**Wärmetauscherkopf für Heater**

Standardwärmetauscher  ja  nein

Temperaturfühler PT100  ja  nein

Temperaturfühler NiCrNi  ja  nein

Geprüft durch: Herrn Schieder

Datum: 13.02.2019



Stecker Renk dreipol  
 Stecker PIN 1 / 93 auf D1 +  
 Stecker PIN 2 / 94 auf D1 -  
 Anschlußkabel SI - Controller  
 Kabel grün auf D1 +  
 Kabel gelb auf D1 -

Diese Zeichnung darf ohne Genehmigung weder vervielfältigt noch an dritte Personen weitergeleitet werden

geändert Datum	Name	Maße und Toleranzen, wenn nicht näher spezifiziert, unterliegen den Eigenarten und Besonderheiten der Glasverarbeitung und werden dem Stand der Technik entsprechend realisiert.	KGW-ISOTHERM 76185 Karlsruhe Tel.0721/958970 Fax.0721/9589777
		Tag: 22.03.2012	Name: W.Schieder
		Maße: mm	unmaßstäblich
		Werkstoff:	Z.Nr:Controller/ Converter USB
			<b>Converter 7561</b>

## 15. Fault Finding with Kaltgas cooling systems

In order to achieve a quick fault detection, we compiled a fault finding that enables the user to localise the occurring fault with the Kaltgas cooling system. The following additional parts are necessary:

- 1 pieces      Dummy plugs for Heater and Jet (the dummy plugs bypass the thermo element monitoring in the heating elements)
- 1 piece        Voltmeter for measuring the ohmic resistance.
- 1 pieces      Data sheets (Jet and Heater), see documents Kaltgas cooling system

### 15.1 Proceeding

First, all electrical data of the heating elements (Jet and Heater) have to be tested with the voltmeter referring to the ohmic resistance, data see “Test Sheet Standard Evaporator”, and with regard to a possible short circuit between heating, thermo element and earth. The results have to correspond with the data on the “Test Sheet Standard Evaporator”.

In case, the resistance data and the short circuit testing do not result in differences, the further testing could be continued.

- 1)      Installation of the Kaltgas cooling system complete with all connection cables.
  - a) Jet (LN2-heating element) – connection cable – safety controller
  - b) Heater (heating element) – connection cable – safety controller
  - c) Temperature probe – extension cord – thermo regulator
- 2)      Now, switch on the safety controller first. The installed alarm signal is audible. Please wait for about 5 seconds, and then press the reset button “Jet” and subsequently the reset button “Heater”. The three lamps above the reset buttons as well as the alarm signal have to be extinct.

If one of the safety circuits cannot be activated by the reset button, the corresponding lamp will not be extinct and the alarm signal is still audible.

The defective safety circuit is determined and the fault finding could be started.

E.g.: The lamp above the “Jet” button is not extinct after the reset. Therefore, the fault has to be found in this particular circuit. Now, the fault finding can be executed step by step:

- 3) Switch off safety controller
- 4) Remove the Jet's extension cord from the safety controller and put one of the dummy plugs in the jack (the thermo element is bypassed). Then switch on the safety controller and activate it according to description under point 2).
  - a) After pressing the reset buttons, the lamp "Jet" is not extinct. Thereby, the safety controller is defective and has to be sent to KGW for inspection.
  - b) If the lamp is extinct at the safety controller, it has to be switched off and the connection cable to Jet will be connected with the safety controller. Afterwards, the dummy plug will be connected with the connection cable and the safety controller will be switched on.
  - c) After pressing the reset buttons, the lamp is not extinct. Then, the connection cable is defective and has to be sent to KGW for inspection. If the lamp is extinct after reset, then, the Jet is defective and has to be sent in for inspection.

The same proceeding can be applied to the Heater. Herewith, it is possible to effect an exact fault detecting and KGW can launch the necessary steps to repair your system.

For further questions, we are at your disposal under 0049 721 95897-77, by fax or under Email: [info@kgw-isotherm.de](mailto:info@kgw-isotherm.de) .

## **16. Declarations of conformity**

### **16.1 Declarations of conformity for the vacuum pump Vacuubrand**

See operating instructions Vaccubrand RZ6 pump

### **16.2 Declarations of conformity for the safety – controller Messner**

Directive electromagnetic compatibility  
(89/336/EEG)

Low tension directive  
73/23/EEG

### **16.3 Declarations of conformity for the temperature controller JUMO**

see manual JUMO B 70.3041.0

### **16.4 Declarations of conformity for the heaters Stegmeier**

Low tension directive  
73/23/EEG

VDE-symbol , checked and certificated to  
DIN EN 60 335 part 1: 1995-10 ( VDE 0700 part 1)

### **16.5 Declarations of conformity of Cryotherm**

liquid nitrogen Dewar vessel with an overpressure more than 0,5 bar.  
Pressure equipment directive 97/23/EG

### **16.6 EMV test**

Test report Nr.: 4514C10

# 17. Construction drawing

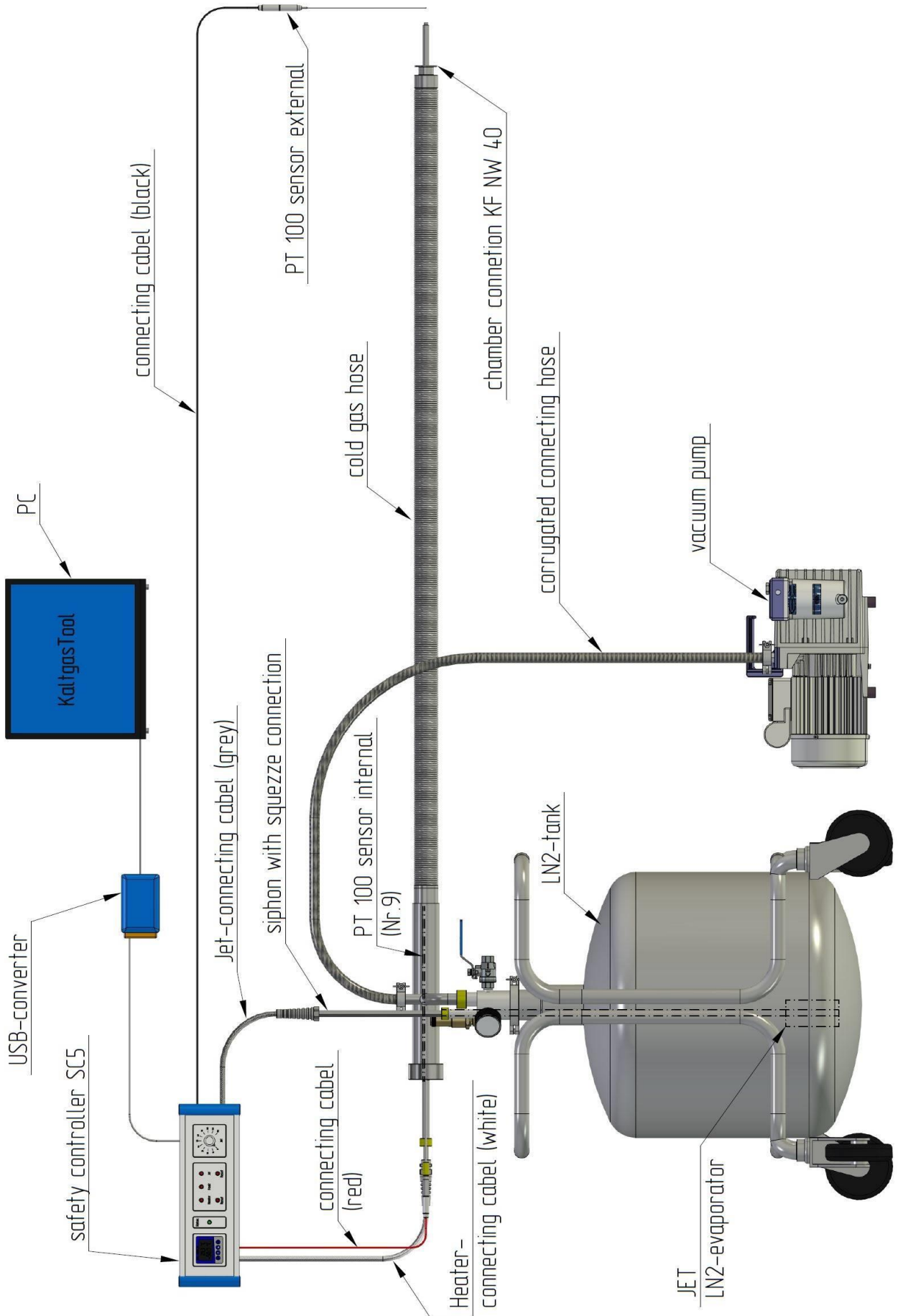

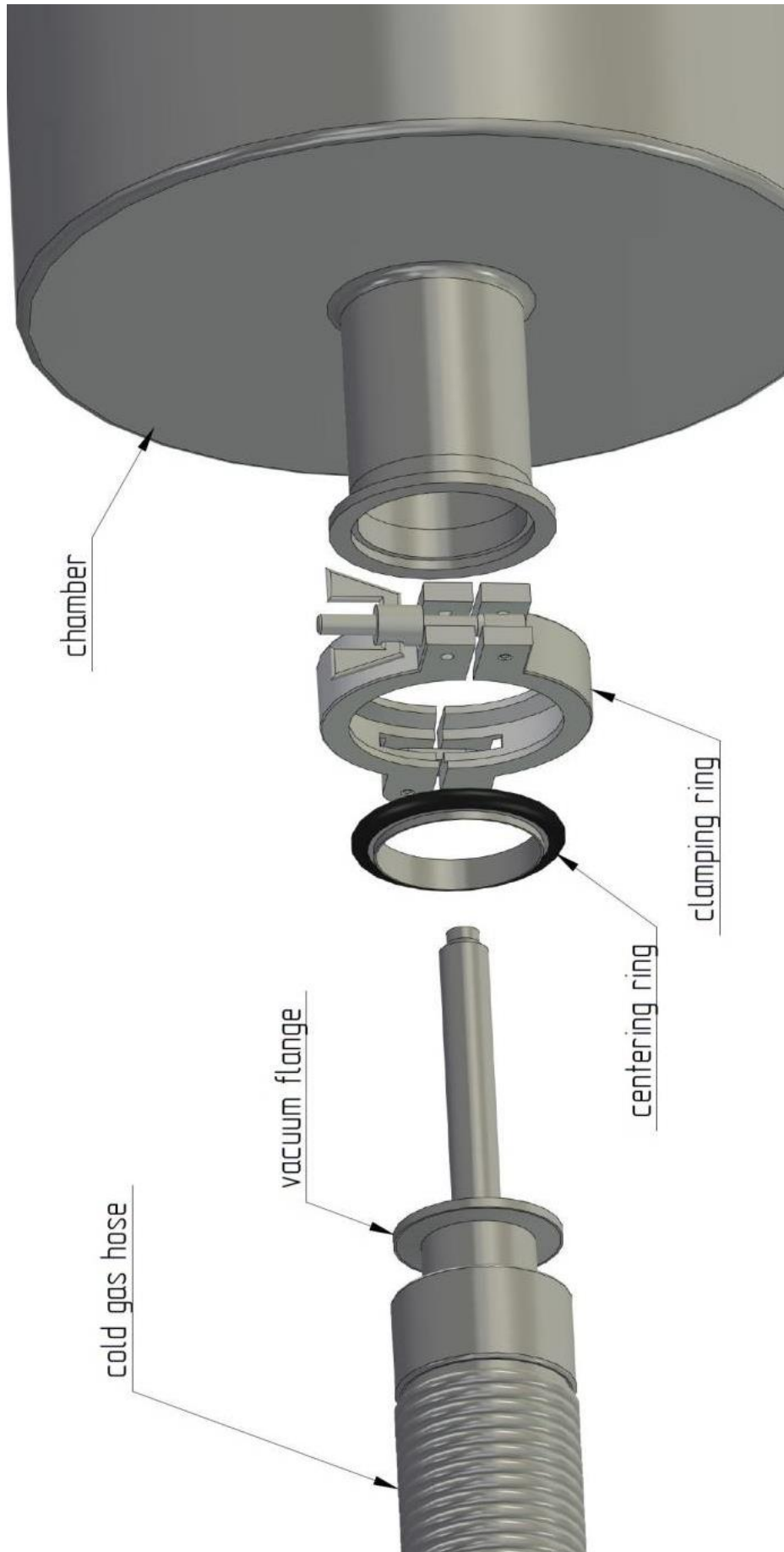

# 18. Detail drawing cold gas hose

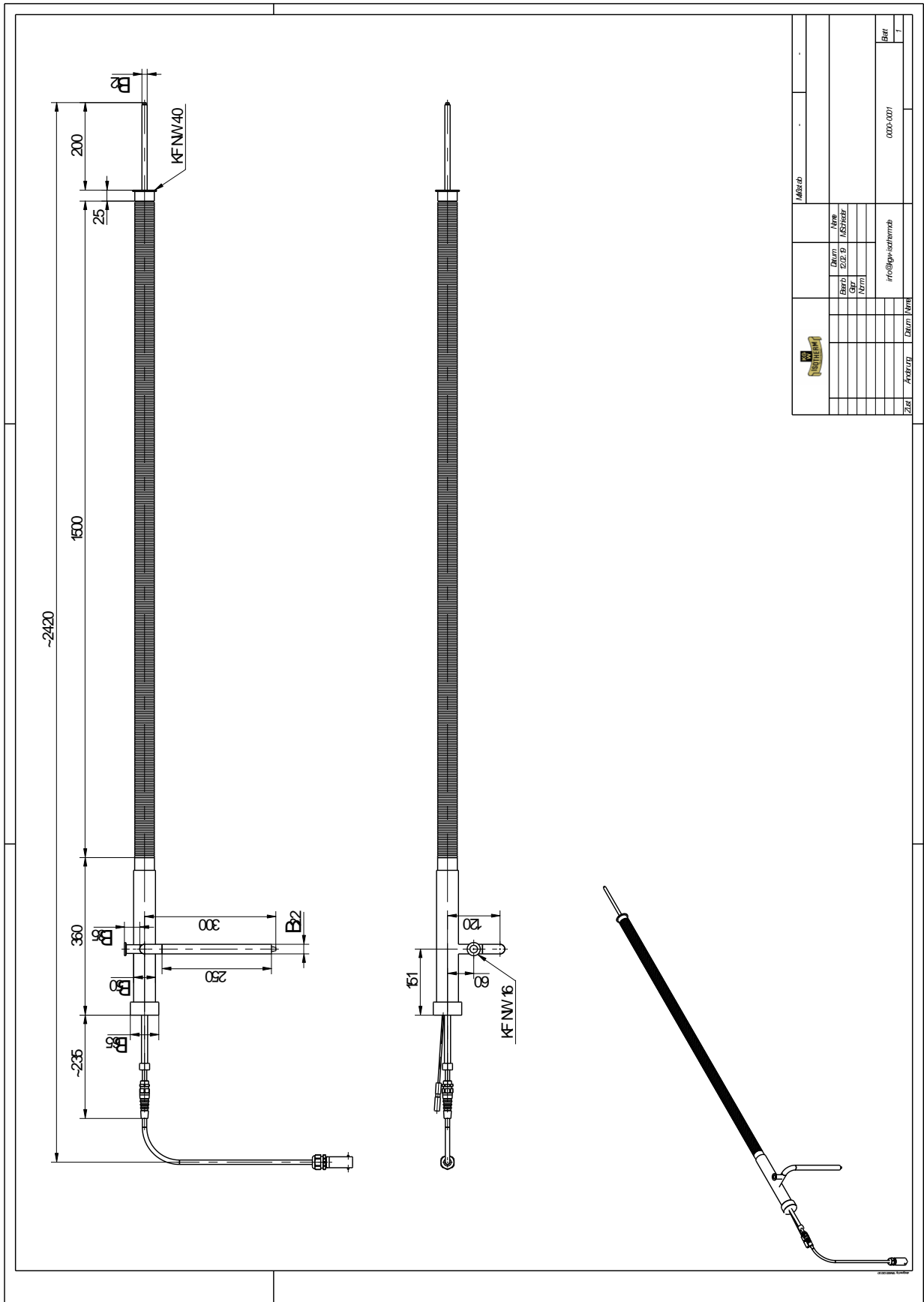

Mischab		Nr		000-001	
Drum	Nr	Drum	Nr	Drum	Nr
Barre	MS/Barre	Barre	MS/Barre	Barre	MS/Barre
Gr	(Gr)	Gr	(Gr)	Gr	(Gr)
Art		Art		Art	
Zust	Art	Zust	Art	Zust	Art

# He- Leak test data

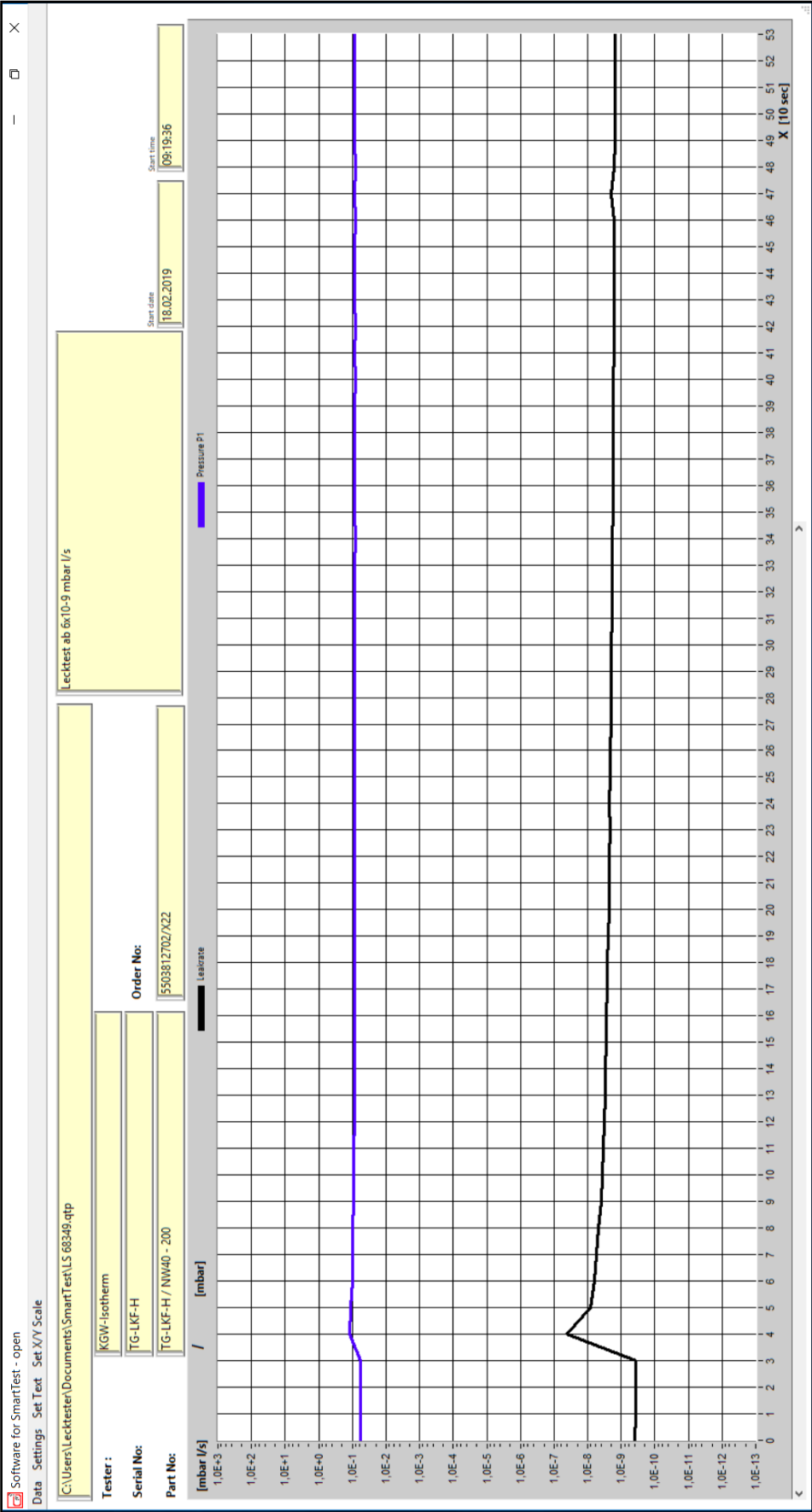

# 19. Test

